

KCMSL

Large format CAM-Unit for punching and bending operations, "Long-Life" design

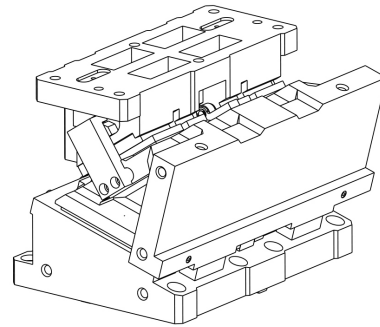
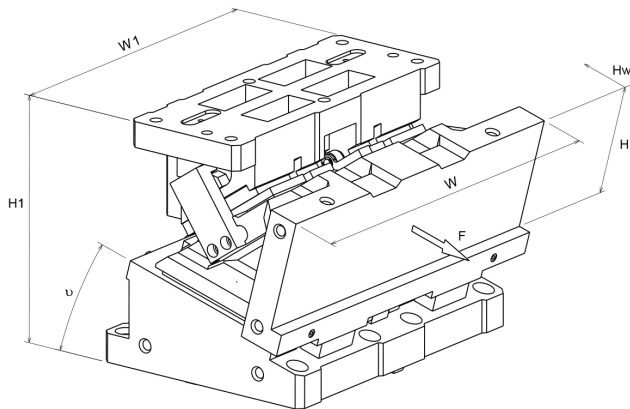

Product description:

Large format CAM-Unit for punching and bending operations, "Long-Life" design

Article properties:

CAM-Type

Die-mounted CAM

Variants:

| Articlenumber | Article name | Cam Width W1 | Shutheight H1 | Working Angle (°) | Work Area Width W | Work Area Height H | Stroke Hw | Working Force F (kN) | Returnforce Fr (kN) | Weight (kg) |
|----------------|--------------|--------------|---------------|-------------------|-------------------|--------------------|-----------|----------------------|---------------------|-------------|
| KCMSL50-217126 | KCMSL500-00 | 500 | 385 | 0 | 500 | 180 | 60 | 313,6 | - | 316 |
| KCMSL50-217127 | KCMSL500-05 | 500 | 385 | 5 | 500 | 180 | 60 | 313,6 | - | 310 |
| KCMSL50-217128 | KCMSL500-10 | 500 | 385 | 10 | 500 | 180 | 60 | 313,6 | - | 306 |
| KCMSL50-217129 | KCMSL500-15 | 500 | 385 | 15 | 500 | 180 | 60 | 313,6 | - | 302 |
| KCMSL50-217130 | KCMSL500-20 | 500 | 385 | 20 | 500 | 180 | 60 | 313,6 | - | 298 |
| KCMSL60-217131 | KCMSL600-00 | 500 | 385 | 0 | 600 | 180 | 60 | 313,6 | - | 325 |
| KCMSL60-217132 | KCMSL600-05 | 500 | 385 | 5 | 600 | 180 | 60 | 313,6 | - | 318 |
| KCMSL60-217133 | KCMSL600-10 | 500 | 385 | 10 | 600 | 180 | 60 | 313,6 | - | 314 |
| KCMSL60-217134 | KCMSL600-15 | 500 | 385 | 15 | 600 | 180 | 60 | 313,6 | - | 310 |
| KCMSL60-217135 | KCMSL600-20 | 500 | 385 | 20 | 600 | 180 | 60 | 313,6 | - | 306 |
| KCMSL70-217136 | KCMSL700-00 | 700 | 385 | 0 | 700 | 180 | 60 | 470,4 | - | 436 |
| KCMSL70-217137 | KCMSL700-05 | 700 | 385 | 5 | 700 | 180 | 60 | 470,4 | - | 429 |
| KCMSL70-217138 | KCMSL700-10 | 700 | 385 | 10 | 700 | 180 | 60 | 470,4 | - | 421 |
| KCMSL70-217139 | KCMSL700-15 | 700 | 385 | 15 | 700 | 180 | 60 | 470,4 | - | 415 |
| KCMSL70-217140 | KCMSL700-20 | 700 | 385 | 20 | 700 | 180 | 60 | 470,4 | - | 410 |
| KCMSL80-217141 | KCMSL800-00 | 700 | 385 | 0 | 800 | 180 | 60 | 470,4 | - | 446 |
| KCMSL80-217142 | KCMSL800-05 | 700 | 385 | 5 | 800 | 180 | 60 | 470,4 | - | 438 |
| KCMSL80-217143 | KCMSL800-10 | 700 | 385 | 10 | 800 | 180 | 60 | 470,4 | - | 430 |
| KCMSL80-217144 | KCMSL800-15 | 700 | 385 | 15 | 800 | 180 | 60 | 470,4 | - | 424 |
| KCMSL80-217145 | KCMSL800-20 | 700 | 385 | 20 | 800 | 180 | 60 | 470,4 | - | 418 |
| KCMSL90-217146 | KCMSL900-00 | 900 | 385 | 0 | 900 | 180 | 60 | 627,2 | - | 571 |
| KCMSL90-217147 | KCMSL900-05 | 900 | 385 | 5 | 900 | 180 | 60 | 627,2 | - | 560 |
| KCMSL90-217148 | KCMSL900-10 | 900 | 385 | 10 | 900 | 180 | 60 | 627,2 | - | 551 |
| KCMSL90-217149 | KCMSL900-15 | 900 | 385 | 15 | 900 | 180 | 60 | 627,2 | - | 543 |
| KCMSL90-217150 | KCMSL900-20 | 900 | 385 | 20 | 900 | 180 | 60 | 627,2 | - | 536 |
| KCMSL10-217151 | KCMSL1000-00 | 900 | 385 | 0 | 1000 | 180 | 60 | 627,2 | - | 579 |

KCMSL

Large format CAM-Unit for punching and bending operations, "Long-Life" design



| Articlenumber | Article name | Cam Width W1 | Shutheight H1 | Working Angle (°) | Work Area Width W | Work Area Height H | Stroke Hw | Working Force F (kN) | Returnforce Fr (kN) | Weight (kg) |
|----------------|--------------|--------------|---------------|-------------------|-------------------|--------------------|-----------|----------------------|---------------------|-------------|
| KCMSL10-217152 | KCMSL1000-05 | 900 | 385 | 5 | 1000 | 180 | 60 | 627,2 | - | 569 |
| KCMSL10-217153 | KCMSL1000-10 | 900 | 385 | 10 | 1000 | 180 | 60 | 627,2 | - | 560 |
| KCMSL10-217154 | KCMSL1000-15 | 900 | 385 | 15 | 1000 | 180 | 60 | 627,2 | - | 551 |
| KCMSL10-217155 | KCMSL1000-20 | 900 | 385 | 20 | 1000 | 180 | 60 | 627,2 | - | 544 |