

## SKCA

Low-cost CAM-Unit for punching and bending operations, High Rigidity with Box Structure

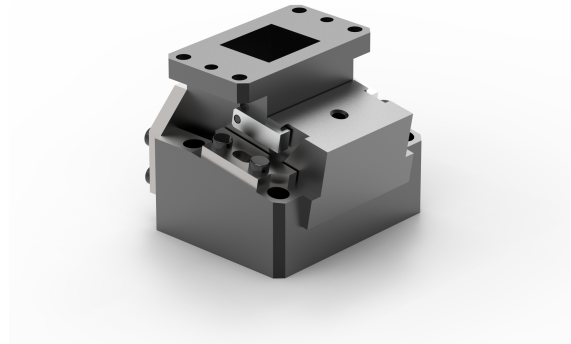
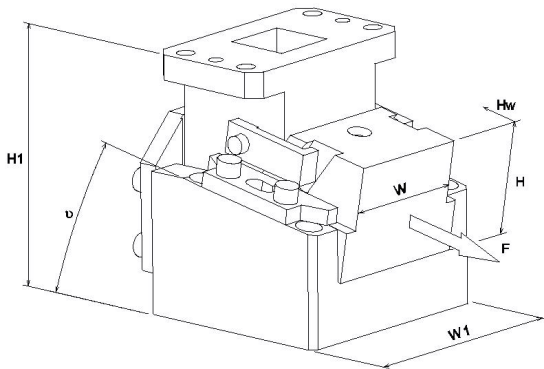

### Product description:

Low-cost CAM-Unit for punching and bending operations, High Rigidity with Box Structure

### Article properties:

CAM-Type

Die-mounted CAM

### Variants:

Articlenumber	Article name	Cam Width W1	Shutheight H1	Working Angle (°)	Work Area Width W	Work Area Height H	Stroke Hw	Working Force F (kN)	Returnforce Fr (kN)	Weight (kg)
SKCA-52-00-25	SKCA52-00-25	98	140	0	52	65	25	14,7	-	8
SKCA-52-00-40	SKCA52-00-40	98	140	0	52	65	40	14,7	-	8
SKCA-52-00-60	SKCA52-00-60	98	140	0	52	65	60	14,7	-	14
SKCA-65-00-40	SKCA65-00-40	130	160	0	65	70	40	19,6	-	20
SKCA-65-00-60	SKCA65-00-60	130	160	0	65	70	60	19,6	-	21
SKCA-65-05-45	SKCA65-05-45	130	160	5	65	70	45	19,6	-	19
SKCA-65-05-70	SKCA65-05-70	130	170	5	65	70	70	19,6	-	22,2
SKCA-65-10-45	SKCA65-10-45	130	170	10	65	70	45	19,6	-	19,6
SKCA-65-10-70	SKCA65-10-70	130	170	10	65	70	70	19,6	-	20,5
SKCA-65-15-45	SKCA65-15-45	130	170	15	65	70	45	19,6	-	22,3
SKCA-65-15-70	SKCA65-15-70	130	170	15	65	70	70	19,6	-	22,3
SKCA-65-20-45	SKCA65-20-45	130	170	20	65	70	45	19,6	-	22,3
SKCA-65-20-70	SKCA65-20-70	130	170	20	65	70	70	19,6	-	21,3
SKCA-100-00-40	SKCA100-00-40	175	200	0	100	90	40	58,8	-	37
SKCA-100-00-60	SKCA100-00-60	175	200	0	100	90	60	58,8	-	38
SKCA-100-00-80	SKCA100-00-80	175	200	0	100	90	80	58,8	-	44
SKCA-100-05-45	SKCA100-05-45	175	200	5	100	90	45	58,8	-	33
SKCA-100-05-70	SKCA100-05-70	175	200	5	100	90	70	58,8	-	38
SKCA-100-10-45	SKCA100-10-45	175	200	10	100	90	45	58,8	-	33
SKCA-100-10-70	SKCA100-10-70	175	200	10	100	90	70	58,8	-	38
SKCA-100-15-45	SKCA100-15-45	175	200	15	100	90	45	58,8	-	33
SKCA-100-15-70	SKCA100-15-70	175	200	15	100	90	70	58,8	-	38
SKCA-100-20-45	SKCA100-20-45	175	200	20	100	90	45	58,8	-	32
SKCA-100-20-70	SKCA100-20-70	175	200	20	100	90	70	58,8	-	39
SKCA-150-00-40	SKCA150-00-40	260	220	0	150	100	40	58,8	-	63
SKCA-150-00-60	SKCA150-00-60	260	220	0	150	100	60	58,8	-	69

## SKCA

Low-cost CAM-Unit for punching and bending operations, High Rigidity with Box Structure



Articlenumber	Article name	Cam Width W1	Shutheight H1	Working Angle (°)	Work Area Width W	Work Area Height H	Stroke Hw	Working Force F (kN)	Returnforce Fr (kN)	Weight (kg)
SKCA-150-05-45	SKCA150-05-45	260	220	5	150	100	45	58,8	-	62
SKCA-150-05-70	SKCA150-05-70	260	220	5	150	100	70	58,8	-	73
SKCA-150-10-45	SKCA150-10-45	260	220	10	150	100	45	58,8	-	63
SKCA-150-10-70	SKCA150-10-70	260	220	10	150	100	70	58,8	-	73
SKCA-150-15-45	SKCA150-15-45	260	220	15	150	100	45	58,8	-	65
SKCA-150-15-70	SKCA150-15-70	260	230	15	150	100	70	58,8	-	77
SKCA-150-20-45	SKCA150-20-45	260	220	20	150	100	45	58,8	-	66
SKCA-150-20-70	SKCA150-20-70	260	230	20	150	100	70	58,8	-	75
SKCA-200-00-40	SKCA200-00-40	310	240	0	200	110	40	78,4	-	82
SKCA-200-00-60	SKCA200-00-60	310	240	0	200	110	60	78,4	-	84
SKCA-250-00-40	SKCA250-00-40	360	270	0	250	130	40	98	-	106
SKCA-250-00-60	SKCA250-00-60	360	270	0	250	130	60	98	-	127
SKCA-300-00-40	SKCA300-00-40	410	270	0	300	130	40	117,6	-	106
SKCA-300-00-60	SKCA300-00-60	410	270	0	300	130	60	117,6	-	128
SKCA-400-00-60	SKCA400-00-60	525	250	0	400	125	60	137,2	-	203
SKCA-500-00-60	SKCA500-00-60	625	250	0	500	125	60	137,2	-	237
SKCA-600-00-60	SKCA600-00-60	725	250	0	600	125	60	137,2	-	279