



Stand-alone changing system

for electrode caps
setup type H and V2

BWS-5710.037.00x

Installation Manual

Translation of the original Installation Manual

ENGLISH – July 18



This Installation Manual constitutes part of the technical documentation of the machine in accordance with the EC Machinery Directive. The suppliers' documentation of the purchased parts supplements this Installation Manual. All documentation is applicable in connection with one another.

The contents of this Installation Manual complies with the "DIRECTIVE 2006/42/EC OF THE EUROPEAN PARLIAMENT AND THE COUNCIL dated May 17, 2006 for machinery and on the amendment to the Directive 95/16/EC (New edition)", Appendix VI.

The Installation Manual is meant for the plant manager, who must hand it over to the employees responsible for using the machine.

The plant manager must ensure that the information contained in these operating instructions Installation Manual and in the accompanying documents has been read and understood.

The operating instructions Installation Manual must be kept in a well-known and easily accessible and handy location, and they must be consulted, even if the slightest doubt arises. As part of the technical documentation, the Installation Manual is archived with the manufacturer as a verification document for a minimum of 10 years!

The manufacturer is not liable for damage to people, animals, or objects or to the machine itself arising from the improper/unauthorized use or through disregard or insufficient consideration of the safety criteria contained in this Installation Manual or through alteration of the machine or use of unsuitable spare parts.

Proprietary notice – copyright in compliance with DIN ISO 16016:2007-12 (technical product documentation - proprietary notices for restricting the use of documents and products)

The copyright in this technical documentation remains with Bräuer Systemtechnik GmbH. This documentation is meant for the operator and his personnel.

Duplication or circulation of this technical documentation as well as utilization and notification of the content is prohibited if not explicitly permitted. Violations shall impose an obligation for compensation.

Status: July 18
Version: 1.0

Bräuer Systemtechnik GmbH
Gewerbegebiet Nord 6
09456 Mildenau
Germany

Telephone: +49 (0) 3733/5967610
Fax: +49 (0) 03733/5967611
Email: info@braeuersysteme.de

This documentation makes use of the following safety symbols and signal words. The combination of a safety symbol and a signal word classifies the respective safety information. The safety symbol can vary depending on the type of danger.

	Symbol	Signal word	Explanation
Death		Danger	This signal word must be used if the non-observance of the respective danger notice may result in death or irreversible damage to health.
Injury and damage to property		Warning	This signal word refers to possible personal and property damage, including hazards of injury, accident and health.
		Caution	This signal word refers to a notice of a danger of property damage. In addition, there is a slight injury hazard.
Fault		Attention	This signal word may only be used if no health hazards can occur. It warns of malfunctions and is not used in combination with a safety symbol since the risk or hazard level is minor.
No damage		Notice/ Important	This signal word points out procedures to facilitate operation, and cross-references. It precludes any risk of property damage and injury hazards and has therefore no warning icon of its own.

1	Identification	1-1
1.1	Intended use	1-2
1.1.1	Instructions for marketing and distribution of the overall system (Integrator)	1-3
1.2	Improper use	1-4
2	General Information	2-1
2.1	Warranty and liability	2-1
2.2	Purpose of the Installation Manual	2-1
2.3	Using the Installation Manual	2-2
2.3.1	Further applicable documents	2-2
3	Safety	3-1
3.1	Structure and visualization of safety notices	3-2
3.2	Emergency situations (fire, accident)	3-3
3.2.1	Procedure in case of fire or during an emergency	3-3
3.3	Safety-oriented behavior	3-4
3.3.1	Personnel qualification	3-5
3.3.2	Operator obligations	3-6
3.3.3	Duties of the personnel	3-7
3.3.4	Personal protective equipment	3-7
3.4	Residual hazards	3-8
3.4.1	Hazards due to electric energy	3-10
3.4.2	Hazards due to mechanical energy	3-12
3.4.3	Hazards due to pneumatic energy	3-13
3.4.4	Hazards due to thermal energy	3-14
3.4.5	Hazards due to emissions	3-15
3.4.6	Hazards due to operating materials	3-16
4	Design and Function	4-1
4.1	General Overview	4-1
4.1.1	Overall diagram – Overview	4-2
4.1.2	Technical Specifications	4-3
4.2	Safety devices	4-4
4.2.1	Protective casings	4-4
4.3	Pneumatic devices	4-5
4.4	Electrical equipment	4-6
4.4.1	Electrical switch box	4-7

4.4.2	Sensor system	4-9
4.5	Mechanical design	4-11
4.5.1	Mechanical design of the BWS 5710	4-12
4.5.2	Mechanical design of the BWS 5700	4-14
4.5.3	Gearbox motor	4-16
4.5.4	Gearbox unit	4-17
4.5.5	Electrode cap extraction unit (Setup type V2)	4-18
4.5.6	Electrode cap cartridge	4-20
4.5.7	Electrode cap collecting box (Setup type H)	4-22
4.5.8	Basic leg stand with height adjustment mechanism	4-23
4.5.9	Electrode cap pressing plate	4-24
4.6	Functional procedure for »Electrode cap change«	4-25
4.6.1	Safety instructions »Electrode cap change«	4-25
4.6.2	Electrode cap change	4-27
4.6.3	Programming the electrode cap pressing plate	4-32
5	Transport, Installation and Connection	5-1
5.1	General safety instructions »Transport, Installation and Connection«	5-1
5.2	Transportation procedure	5-2
5.2.1	Transport with a forklift	5-2
5.3	Unpacking the machine	5-4
5.4	Erecting and assembling the machine	5-8
5.4.1	Operating and ambient conditions	5-9
5.4.2	Work, service and protected areas	5-9
5.4.3	Space requirements	5-10
5.4.4	Setting up the machine	5-11
5.4.5	Setting up the machine (Height adjustment of the basic leg stand)	5-12
5.5	Connecting the machine (Energy supplies)	5-14
5.5.1	Pneumatic connection	5-15
5.5.2	Electric connection	5-18
5.5.3	Connection of the control/EMERGENCY STOP circuit	5-20
6	Start-up and Settings	6-1
6.1	General safety instructions »Start-up and Settings«	6-1
6.2	Workstations and tasks of the personnel	6-2
6.3	Control elements	6-3
6.3.1	Main switch (optional)	6-3
6.4	Start-up tools	6-4
6.4.1	Programming the »Electrode cap changing system«	6-5
6.4.2	Visual inspections before putting into operation	6-7
6.5	Filling the electrode cap cartridge (Initial filling)	6-8

Table of Contents

6.5.1	Filling operation	6-10
6.6	Switching off the machine	6-11
6.7	Restarting after occurrence of a fault	6-11
7	Decommissioning	7-1
7.1	Decommissioning and storing the machine	7-1
7.2	Decommissioning and disposing of the machine	7-2
8	Setup and Tool Installation	8-1
8.1	General safety instructions »Setup and tool installation«	8-1
8.2	Tool change	8-2
8.2.1	Replacing the electrode cap changing head (Service)	8-2
8.3	Restarting after retrofitting	8-6
9	Maintenance and Service	9-1
9.1	Preparatory works	9-2
9.1.1	Repair shipping	9-3
9.2	Cleaning and Care	9-3
9.2.1	Cleaning work	9-3
9.2.2	Finishing the cleaning work	9-5
9.3	Maintaining the pneumatic equipment	9-6
9.4	Maintaining the electrical equipment	9-7
9.5	Lubrication	9-8
9.5.1	Lubricating the gear unit	9-8
9.6	Maintenance plan	9-9
9.6.1	Maintenance plan - Qualified personnel	9-10
9.7	Manufacturer service	9-12
9.7.1	Spare parts ordering	9-12
9.8	Finishing the maintenance work	9-13
10	Faults	10-1
10.1	Procedure for malfunctions	10-2
10.2	Troubleshooting	10-3
10.3	Restarting after fault rectification	10-3

11	Appendix	11-1
11.1	Index	11-1
11.2	Safety symbols (DIN EN ISO 7010)	11-3
11.2.1	Warning symbols	11-4
11.2.2	Prohibition symbols	11-4
11.2.3	Mandatory signs	11-6
11.2.4	Hazard symbols	11-7
11.2.5	Rescue symbols	11-8
11.2.6	Other symbols	11-8
11.3	Further documents	11-9
11.4	Plans (Lubrication)	11-10
11.5	Drawings (Electrical circuit diagrams)	11-10
11.6	Spare parts lists	11-10

1

Identification

1 Identification

The section »Identification« contains important information on the identification of the machine as well as the manufacturer's contact details. The intended and improper uses of the machine are defined and described here.

Designation	Stand-alone changing system for electrode caps Setup type H and V2
Machine no.	BWS-5710.037.00x
Serial no.	Document valid from serial number: 000000114
Year of manufacture	2017
Service life	The machine is designed for a service life of 10 years in 3-shift operation. Thereafter, the machine should undergo inspection.
Manufacturer	Bräuer Systemtechnik GmbH
	Gewerbegebiet Nord 6 09456 Mildenau – Germany
Telephone	+49 (0) 3733/5967610
Fax	+49 (0) 03733/5967611
Email	info@braeuersysteme.de
Website	www.braeuersysteme.de

1.1 Intended use

The machine is used for automatic changing of the electrode caps of a moving welding gun, which is fed to the changing system. The machine is used only for deployment within a welding cell that is inaccessible during automatic mode. The machine »Stand-alone changing system for electrode caps BWS-5710.037.00x« is manufactured in two setup types:

- Setup type H with horizontally arranged gear unit
- Setup type V2 with vertically arranged gear unit and with cap extraction unit

The machine is used only to change electrode caps made of copper materials. The type-dependent changing head pulls out each of the electrode caps. The welding gun removes new caps from the top of cap cartridge. The caps are pressed hard with a specific force on the cap pressing plate when the welding gun is closed.

The machine is meant only for use in a non-explosive atmosphere, integrated into an overall system (safety circuit, control circuit) by maintaining the safety and protective concept. It is permitted to use the machine only indoors. The machine is meant only for commercial/industrial use.

Any other use of the machine or use beyond its intended purpose is considered unintended and thus improper. In this case, the safety mechanisms and the protection of the machine may be compromised. The company Bräuer Systemtechnik GmbH assumes no liability for any damage resulting from such cases!

The intended use also includes

- following all instructions in this Installation Manual.
- compliance with all safety notices and icons at the machine and in this Installation Manual (including the instructions given in the suppliers' documentation for the machine components), as well as
- complying with the inspection and maintenance work.

WARNING	
	<p>Danger in case of improper use</p> <p>There are hazards (injuries, damage to property and interruption in the operation) resulting from any improper use of the machine.</p> <ul style="list-style-type: none">• Use the machine exclusively in accordance with the intended use!

1.1.1 Instructions for marketing and distribution of the overall system (Integrator)

As an incomplete machine in the context of the Machinery Directive, the machine has no control and safety devices of its own. The machine must be integrated into a higher-level control and EMERGENCY STOP concept.

IMPORTANT



Nameplate and conformity

The machine »Stand-alone changing system for electrode caps BWS-5710.037.00x« does not represent a ready to use machine on its own, and hence, it is evaluated as a so-called incomplete machine in the context of the »Machinery Directive« 2006/42/EC.

The machine is provided by Bräuer Systemtechnik GmbH with the declaration of incorporation in accordance with the Machinery Directive 2006/42/EC and EMC Directive 2014/30/EU in the market. There is no CE mark applied on the nameplate of the machine.

To begin with, the integrator must the machine properly and in conformity with the standards and then, finally undertake providing the CE mark for the entire system or issue a declaration of conformity in accordance with the »Machinery Directive« 2006/42/EC, Appendix IIA and EMC Directive 2014/30/EU. The nameplate present on the entire system must then bear the CE mark. When doing so the information given in the following must be added to the Installation Manual of the machine.

The following safety devices come under the scope of responsibility of the integrator. These are not an integral part of the scope of supply of Bräuer Systemtechnik GmbH.

- Devices that can be locked (e.g. with a padlock) must be provided for disconnecting the power supply for pneumatic and electrical energy. In addition, blocking devices must be provided for the cooling water supply (welding gun cooling).
- The changing system must be secured with protective equipment (e.g. protective fence). These must meet the requirements of EN 14120 and EN 13857.
- The control of the entire system must be conceived in such a way that movements of the machine in automatic mode are possible only if all the above-mentioned protective equipment are in the protective position (e.g. safety doors must be closed, contactless disconnecting or isolating equipment must be active).
- The control of the entire system must be conceived in such a way that in automatic mode, any unexpected start-up of any electric or pneumatic actuators is prevented assuredly when the protective equipment is not in the protective position. This safety function must be at least equivalent to $PL_r=c$ according to EN 13849-1 for the drive motor and $PL_r=a$ for the pneumatic actuators.
- In the danger zone, at least one clearly visible and easily accessible device must be provided to bring the machine to standstill in case of an emergency (EMERGENCY STOP). This safety function must achieve at least $PL_r=c$.
- The residual risks from the Installation Manual of the electrode cap changing system must be incorporated into the operating manual of the entire system.

1.2 Improper use

Types of improper use that may result in hazards for the personnel working at the machine, third parties or for the machine itself, for all operating modes include:

- use of the machine and its electrical equipment contrary to its intended use,
- machining electrode caps and materials whose shape, dimensions and material deviates from the shape, dimensions and the materials that can be machined described in the data sheet,
- machining electrode caps that no longer have adequate thickness,
- machining electrode caps or electrode caps with residual seams,
- using cap cartridges other than those mentioned in the data sheet,
- inserting foreign objects or tools in the electrode cap changing system,
- putting the machine back into operation after maintenance, cleaning or repair work without prior checking for proper assembly and installation,
- ignoring the operational instructions,
- ignoring the Installation Manual,
- modifying the machine as well as additions to or alterations of the same without the prior consultation with Bräuer Systemtechnik GmbH,
- operating the machine beyond the physical limits of deployment and the environment as well as other operational conditions (e.g. working temperature, deployment in an environment prone to fire, use in humid rooms),
- operating the machine in private, non-commercial/non-industrial areas,
- operating the machine contrary to the provisions in this Installation Manual regarding safety instructions, installation, operation, maintenance and service, setup and fault rectification,
- disassembling, bypassing or disabling safety and protection devices of the machine,
- operating the machine after the occurrence / in the presence of obvious faults,
- carrying out repair, cleaning and maintenance work without the machine being switched off first as well as
- the deployment of the machine in an explosive atmosphere.

WARNING



Danger in case of improper use

There are hazards resulting from unauthorized modifications of the machine and the use of spare parts from unauthorized manufacturers.

Improper use of the machine may lead to severe injuries and / or damage to property.



- Use only the manufacturer's original spare and wear parts! Do not carry out any modifications, additions or alterations to the machine without the approval of Bräuer Systemtechnik GmbH! This also applies to welding works on load-bearing parts.
- Use the machine exclusively in accordance with the intended use!

Hazards may arise with improper use. Improper use occurs, for example, if you:

- manipulate or bypass limit switches or other safety or protective devices
- use impermissible tools, workpieces and materials
- operate it improperly
- rectify faults improperly
- ignore the measures for care and maintenance
- do not remove tools and workpieces from the working area of the machine after carrying out maintenance work.

WARNING



Risk of injury and likelihood of damage to property by ignoring the safety instructions

There are hazards resulting from ignoring the operating manual or any safety instructions contained herein, as well as any notices and icons on the machine.



- Carefully read the Installation Manual before the initial start-up!
- Comply with the required safety conditions before the initial start-up!
- All safety instructions and hazard warnings on the machine must be observed and must always be maintained in a fully legible condition.
- All rules and regulations applicable for accident prevention must be observed!

2

General Information



2 General Information

The section »General instructions« contains important information on using the technical documentation and on the warranty.

2.1 Warranty and liability

The »General Terms and Conditions of Sale and Delivery« of Bräuer Systemtechnik GmbH apply on principle. They have been made available to the owner since the contract was signed at the latest.

Warranty and liability claims for personal injury and material damage are excluded if they are attributed to one or more of the following causes:

- improper use of the machine,
- improper assembly and installation, commissioning, operation and maintenance of the machine,
- operating the machine with defective safety devices or without them,
- ignoring the instructions in the Installation Manual,
- unauthorized structural modifications of the machine.
- poor maintenance, repair and servicing regime,
- disastrous events due to the effect of foreign bodies or force majeure

2.2 Purpose of the Installation Manual

This Installation Manual serves as a support and contains all the required information and instructions that need to be observed in terms of general safety, transport, installation, operation, maintenance and setup.

The Installation Manual with all safety notices (as well as all additional documents pertaining to the machine components from third-party suppliers) must be

- observed, read and understood by all persons working on the machine (in particular, knowledge of the safety information and instructions)
- freely accessible to everyone and anyone,
- consulted in the case of the slightest doubt (with regard to safety issues).

Objectives:

- to prevent accidents
- to increase the service life and reliability of the machine
- reduce the times of standstill

2.3 Using the Installation Manual

This Installation Manual is part of the technical documentation and legally required part of the scope of supply of the machine in compliance with the Machinery Directive 2006/42/EC.

The following criteria need to be met for compliance with the requirements of the Machinery Directive:

- the operating manual must be read by every one of the personnel working on and with the machine before using it for the first time
- if the operating manual is lost, the company operating the machine is under the obligation to procure and provide a new copy
- if the machine is sold on to a third party, the operating manual and all supplementary documents must be handed over in full

2.3.1 Further applicable documents

In addition to the safety instructions given in this Installation Manual, the provisions of accident prevention regulations of the employer's liability insurance association are basically applicable to all work on the machine.

In addition to this instruction manual, Installation Manual the following documents must be observed for a safe operation as intended:

- suppliers' documentation of the machine components
- documentation in the Appendix of this Installation Manual (drawings, connection diagrams, etc.)
- the legally applicable and binding accident-prevention regulations
- applicable mandatory regulations at the site of use (operating instructions)
- the recognized technical regulations for safe and professional working methods
- existing provisions on environmental protection and other relevant provisions

NOTICE



Observe and follow the suppliers' documentation

In addition to this instruction manual, Installation Manual the technical documentation for the purchased parts must also be observed! It is included in the scope of supply of this technical documentation.

In particular, the following need to be observed in the suppliers' documentation:

- Safety notices / Warnings and maintenance notices
- Overview of the suppliers' documentation ► chapter **Fehler! Verweisquelle konnte nicht gefunden werden.**

WARNING



Risk of injury posed by ignoring the safety instructions and safety icons in the suppliers' documentation

There are hazards resulting from ignoring the safety instructions given in the supplementary suppliers' documentation.



- Always observe the safety notices and safety icons!
- Instructions and information on operation, maintenance etc. must be observed and followed in all respects!
- When in doubt, the corresponding suppliers' documentation must be





consulted before starting work on the machine components!

3

Safety

3 Safety

The "Safety" chapter contains important safety-related information for working with the machine. It describes particular hazardous sources found during specific phases during the life cycle, as well as the remaining risks as determined.

WARNING	
	<p>Risk of injury and damage to property by ignoring the safety instructions and information</p> <p>There are hazards resulting from any failure to observe the instruction manual Installation Manual and any safety notice contained herein, or any notices and signs on the machine.</p>
	<ul style="list-style-type: none">• Carefully read the Installation Manual before the initial start-up!• Comply with the required safety conditions before the initial start-up!• Observe the general safety notices and also the special safety notices included in the other sections!

The machine has been constructed using state-of-the-art technology and in line with established safety regulations. To rule out hazards for the life and limb of the personnel and any third parties, as well as damage to the machine itself, it should be operated only in accordance with the intended use and in a clearly flawless condition with regard to safety.

Bodily injuries and property damages resulting from non-compliance with the instructions provided in the Installation Manual are the responsibility of the company operating the machine or the persons assigned by it.

Faults that may compromise safety must be eliminated without delay.

All safety instructions and hazard warnings on the machine must be observed and must always be maintained in a fully legible condition.

3.1 Structure and visualization of safety notices

Hazardous situations are pointed out in this Installation Manual as well as directly at the hazardous spots on the machine using safety notices and safety icons. All safety notices have a uniform structure. The hazardous area is classified through colors, icons and warnings.

A safety notice is structured as follows. The safety notice consists of a signal word, an icon, a color bar and a text message with a black border.

There are generally four different levels of warning, identified by the following signal words and colors:

DANGER	immediate danger to life
WARNING	potential danger to life, or injury hazard
CAUTION	potential injury hazard
ATTENTION	potential damage to property
NOTICE	no hazards / no damage to property

WARNING



Risk of injury by ignoring safety notices and safety icons

There are hazards resulting from any failure to observe the safety notices in this operating manual, the pertaining documentation, as well as the notices and icons on the machine.



- Always observe the safety notices and safety icons!
- Safety notices and symbols that have become illegible or were removed are to be replaced without delay!

The relevant safety symbols used in this Installation Manual as well as directly at the hazardous areas on the machine require particular attention depending on the combination of signal word and icon.

3.2 Emergency situations (fire, accident)

Emergency situations may occur at the machine, caused by various impacts and faults, in which conscious and discreet action by the personnel is important.

ATTENTION



Emergency situations

The personnel working at the machine must participate in first-aid courses at regular intervals!

Keep all safety devices

- with regard to rescue procedures (first-aid kits, rescue routes, stretchers),
- the machine (EMERGENCY STOP push button, main switch, fuse boxes, etc.),
- with regard to fire protection (fire extinguishers, smoke and heat extraction units, manual fire alarms),
- and the usual traffic routes



accessible and free of obstructions!

The operating instructions of the machine operator regarding the behavior in emergency situations (fire, accident) must be adhered to without exception!

- The following information is merely generally applicable recommended behavior as issued by the standardization institutes.

3.2.1 Procedure in case of fire or during an emergency

1. Keep calm and try to stay aware of your surroundings!
2. Pay attention to your own safety (accidents caused by electricity, conductivity)!

	Type of accident	Measures
	Hazardous substance	<ul style="list-style-type: none"> • See the specific guidelines in the operating manual!
	Fire	<ul style="list-style-type: none"> • Attempt to extinguish the fire! • Observe the fire protection regulations!
	Electrical components	<ul style="list-style-type: none"> • Alert rescue services! • Use heart-lung resuscitation technique!

3.3 Safety-oriented behavior

Responsible behavior on the part of the machine operator and the personnel (from all fields of expertise) working at the machine are the prerequisite for the machine safe operation.

The safety of the machine depends on the attention, precaution and common sense of all persons installing, operating and maintaining the machine . Apart from observing the safety precautions listed, you basically need to exercise caution near the machine. To prevent accidents, the following must be observed:

- local general safety regulations according to the respective country
- regulations specific to the operator and the area of application
- specific agreements reached with the operator
- separate safety notices that came with the machine
- safety symbols and notices affixed to the machine and its packaging

The following circumstances could increase the potential hazards of the machine :

- failure of important functions of the machine
- failure of prescribed methods of operation, maintenance and servicing
- endangering of persons through electric or mechanic effects
- endangering due to negligent behavior of the company operating the machine and/or of the personnel working on the machine

3.3.1 Personnel qualification

Only qualified personnel may carry out work on the machine .

Only those persons who have the appropriate qualification based on their education should work with the machine. Over and above this, these persons must be briefed and trained in the peculiarities of the machine. Attention must be drawn to the machine-specific hazard locations (residual risks) during briefing and training.

Personnel to be trained, taught, briefed or those undergoing general training should be working on the machine only under constant supervision of an experienced person.

Work on the electrical equipment of the machine should be undertaken only by an electrician or by trained persons under the guidance and supervision of an electrician in accordance with the rules of electrical engineering.

The Installation Manual is directed at personnel from the following fields of expertise:

Area of responsibility	Competence
Transport	Specialists*
Assembly / installation / dis-assembly / commissioning	Specialists*
Operation / decommissioning	Operating personnel**
Setup	Specialists*
Maintenance and service	Specialists*
Troubleshooting	Specialists*

*Specialists

A person who, based on his technical education, experience and training has sufficient knowledge about safety regulations, accident prevention regulations, guidelines and acknowledged and approved engineering practices (e.g. VDE provisions, DIN standards). The specialist must assess the work entrusted to him, must be able to identify and prevent potential hazards, and must be authorized by the person responsible for the safety of the machine to carry out the work and activities necessary.

**Operating personnel

Persons who receive training from a qualified member of personnel concerning their assigned tasks and potential dangers in the case of improper conduct and if necessary, are trained and instructed in the necessary protective equipment and protective measures.

3.3.2 Operator obligations



The machine must be in a safe condition and used safely to ensure the safe operation. Consequently, the owner is obligated to ensure that the following instructions are complied with:

- Ensure that the machine is operated by qualified and authorized personnel only! The minimum legal age must be observed!
- Dangerous work methods that impair safety must be prohibited! Check the conduct and performance of the employees!
- Ask for a written confirmation of the employees that they have understood the Installation Manual !
- Ensure that a copy of the complete Installation Manual is always ready at hand at the machine !
- Regular review of the Installation Manual for completeness and legibility!
- For activities with increased risk of injury, appropriate personal protective equipment (PPE) must be worn!
- Precisely specify field of duties and responsibilities (e.g. operation, maintenance)!
- Permit access to danger zones of the machine only to briefed/instructed and authorized qualified personnel who are familiar with the potential risks, reactions and procedures involved!
- Immediately report any detected safety deficiencies which arise to the supervisor!
- Comply with applicable local provisions!

Local provisions:

- personnel safety (accident prevention regulations)
- the safety of working equipment (protective clothing and maintenance)
- disposal of products and materials (regulations on waste)
- Cleaning (waste disposal and environmental protection legislation)

WARNING

Risk of injury caused by human misconduct or by lack of/insufficient personnel qualification

There are hazards resulting from improper operation due to lack of qualification or general human error at the machine.

- The operator must regulate work at the machine with binding operating instructions!
- Maintenance/Cleaning works and fault elimination may be performed by qualified personnel only!
- Work on energy and resources supply may be performed by qualified personnel only!
- Personnel working at the machine is to be trained at regular intervals and made aware of the hazards and incorporated safety devices!



The briefing of the personnel with regard to hazards and the required protective measures to be taken must be repeated at regular intervals, at least once per year, by the company operating the machine.

Operating instructions are necessary for the concerns of occupational safety that the company operating the machine has to prepare! These instructions must be observed to their full extent by the machine operator – in addition to the Installation Manual!

3.3.3 Duties of the personnel

The operating personnel is obligated to contribute to the prevention of work accidents and their consequences through their own behavior at work.

WARNING

Risk of injury caused by lack of/insufficient qualification or authorizations of the personnel

There are hazards for persons and the proper operation of the machine resulting from insufficiently qualified personnel.

There are hazards due to unauthorized actions as well as disregard of operating instructions and authorizations.

- The machine must be operated by instructed personnel only! New operating personnel must be familiarized with the procedures by the existing operating personnel! The operator must regulate precisely the area of responsibility, scope of authority and monitoring of each personnel member!
- Work and operating instructions as well as applicable accident prevention regulations must be observed!
- The personnel from the various fields of expertise must have the corresponding qualification for such works (training, instruction, briefing). If required, this may be done by the manufacturer as commissioned by the operator! In the case of non-observance, all warranty claims become void!
- Intervention by unauthorized personnel on the machine's controls is prohibited in any case! Do not perform any activities for which you have not received authorization! Consult qualified personnel!
- Wear personal protective equipment (PPE)!

3.3.4 Personal protective equipment



The personnel working at the machine (operating and maintenance personnel) must wear appropriate personal protective equipment (PPE) during the operating, maintenance and repair activities. Wearing protective equipment (PPE) is required by this Installation Manual at various points (mandatory signs).



3.4 Residual hazards

During set up and normal operating mode, and if a defect occurs, as well as during service and cleaning work it may lead to hazardous situations with varying hazardous potentials at the machine due to energy being released. Despite the electronic and mechanical protective measures adopted, the company operating the machine needs to define additional organizational measures to ensure safe operation.



Even if all precautions have been taken, there may be residual risks at the machine which are not immediately apparent and if ignored, lead to death or severe injuries. Even after the machine has been switched off, residual energy may still reside within cables, lines and equipment.

- Remaining risks can be reduced by observing the safety notices, the intended use and the Installation Manual !
- For the concerns of occupational safety, operating instructions are necessary (specifying handling and operation of the machine), which must be prepared by the company operating the machine!
- The personnel working at the machine must be made aware of the hazards during training sessions held at regular intervals!

WARNING	
 	<p>Danger due to faults</p> <p>On principle, there are always hazards of all kind resulting from faults at the machine .</p> <ul style="list-style-type: none"> • In the event of faults or operating conditions, which could compromise the safety of the personnel, it is mandatory to stop the machine by disconnecting the power supply! • The professional restoration of the proper working condition is required!

WARNING	
  	<p>Fire hazard</p> <p>There is always a fire hazard in the immediate vicinity of the machine, if combustible detergents or oils come into contact with open flames or if equipment catches on fire (electric equipment).</p> <ul style="list-style-type: none"> • Fire, open flames and smoking in the vicinity of the machine are prohibited at all times! • Combustible liquids may never be stored within the danger zone of the machine !

WARNING

Risk of falling or slipping posed by leaking operating materials, contaminations and incorrectly laid hoses and cables

Discharged operating materials and cooling water (welding gun cooling) or other contamination (e.g. lubricants from gear units, small parts or similar) due to defects in the machine pose a risk of injury if the personnel slips and falls.



Risk of stumbling posed by electrode caps, cables or hoses lying on the ground. Since the welding gun is water-cooled, there is also the risk of slipping posed by cooling water that has leaked out.

- Discharged materials must be removed immediately! Clean the working area regularly (at least once a day)!
- Cooling water that has leaked out must be absorbed promptly!
- Lay the cables and hoses in such a way that no stumbling spots occur!
- Once a week, the machine must be checked for its safe condition as well as loose parts or torn cables supplying power to the equipment!
- Rough parts or small parts and electrode caps must be picked up from the floor!
- The supply of cooling water must be blocked before changing the electrode caps!
- Wear personal protective clothing!

The following overview table contains examples of some hazards posed by the various energy sources.

Source of dangers	Example
Electrical energy	electronic components and freely accessible energized devices
Mechanical energy	Drives, moving components (changing head, gear wheels, gear unit, etc.)
Thermal energy	hot surfaces of drives, fires, etc.
Residual energy	residual thermal, mechanical and electric energy in cables and devices after shutting down the machine
Emissions	Air-borne sound (noise), dust

DANGER

Danger to life due to released energies



Various hazards with different hazardous potential may arise at the machine which cannot be prevented despite having taken protective measures.

- While working on the machine or the connections of its equipment (electrical connections), the power supply must be disconnected and the machine must be secured against being restarted!
- Repair work on the machine should be carried out only by specialists!

3.4.1 Hazards due to electric energy

The power supply to the machine components is fed via the electrical connecting cable in the electrical switch box of the machine. For this purpose, the connector of the connecting cable must be inserted into one of the (suitable) sockets provided for the machine in the installation area and thus establish the electrical connection.

DANGER

Danger to life due to electric shock in the event of contact with energized electric devices due to human error or lack of qualification

Touching live conductors or components that carry the intended voltage, or in case of contact with live conductors or components that carry voltage in faulty condition (in particular due to insulation faults), as well as due to electrostatic processes such as touching statically charged components, may result in danger to life due to electrical shock!

There is a risk of fire, electric shock, burns and death if people approach live components, especially in the high voltage area.

After switching off the machine, remaining electric energy still resides in the lines, devices and components for approx. 5 minutes.

The electrical switch box contains live parts. Opening the door of the electrical switch box may cause death, serious injuries or damage to property caused by electric shock. The main feed terminals are energized, even if the main switch is turned off.

Non-compliance (such as freely accessible contacts, incorrect installation of the earth line, etc.) can result in electric shock and ultimately in the most severe injuries (cardiac arrhythmia, severe burns, blindness) and death!

- Observe a safety clearance around energized cables and avoid contact with them under any circumstances!
- Have work at the electric supply or at freely accessible energized devices performed only by qualified electricians and with the power switched off! Disconnect the machine from the main power supply and secure against unintentional restart, if running parts of the machine can be accessed using tools.
- Keep the electrical switch box locked at all times! Intervention is permitted for authorized personnel only!
- Check the electrical equipment of the machine at regular intervals (inspection (every 4 years in accordance with DGUV REGULATIONS 3)! Replace singed or scorched cables! Inspect insulation of all moving cables for damage at regular intervals during repair and maintenance works! Eliminate loose connections!
- Regular safety briefings with the operating personnel about the risk of the remaining power.

DANGER



Danger to life due to electric fires, spraying of melted components, chemical reactions and gas emissions

Cable breaks, disconnection of terminals or of other electrical contacts as well as overload may cause a fire hazard.



There is danger to life due to electric shock resulting from attempts to extinguish electric fires using water.



- If possible, switch the machine – off before starting fire-fighting measures!
- Never extinguish electrical fires with water! Fire fighting with CO₂!
- Check the electrical equipment of the machine at regular intervals (inspection every 4 years in accordance with the DGUV REGULATION 3)! Replace singed or scorched cables! Inspect insulation of all moving cables for damage at regular intervals during repair and maintenance works! Eliminate loose connections!

DANGER



Danger to life due to faulty earthing

There are hazards due to electric energy if the machine is not grounded, or not grounded properly.



- Have the earthing carried out by qualified electricians only!
- Connect the earthing device of the machine with the site's earthing system, i. e. produce equipotential bonding between the machine and the site!
- Check the integration of the site before the power is switched on for the first time!



3.4.2 Hazards due to mechanical energy

Moving machine components may cause severe personal injuries and serious damage to property, e.g. by entanglement and pulling in as well as crushing.

WARNING

Hazards while intervening in freely moving machine components

There is the risk of crushing or amputation posed by ignoring the danger zones and the safety clearance to moving components of the machine. Removing protective casings or bypassing, disassembling or manipulating electronic safety equipment may lead to unobstructed intervention in the moving machine components.







- Never remove or open protective casings under any circumstances!
- Never bypass, disassemble or manipulate any electronic safety equipment!
- Observe the danger zones and hazard warnings at the machine ! The required safety clearance of 800 mm around the machine components must be observed!
- Never reach into moving machine components!

WARNING

Risks posed by getting pulled in or entangled when getting caught by pulling, rotating or winding machine components (e.g. rotating »changing head«)

There is the risk of injury if pieces of clothing, jewelry or hair is pulled in by moving components of the machine (rotating machine tool).



Ignoring the danger zone and the safety clearance to the machine as well as the removal of protective casings pose this kind of risk.

- Never remove or open protective casings under any circumstances!
- Wear tight-fitting clothing!
- Long belts, ties, scarves and loose-fitting clothing, as well as jewelry (necklaces, bracelets, loose fitting watches) must be removed before starting work on the machine!
- Wearing protective headgear (hair net, cap, hood) is a way of preventing the hazard of getting caught and tangled!

WARNING

Risk of suffering crushing injuries by movements of the electrode cap changing system

Risk of crushing posed by the movements of the components of the machine if this is not secured with isolating protective devices.





Risk of crushing posed by the movements of the components driven with the help of pneumatic or electrical energy if they start up unexpectedly.

- Movements of the components should be executed in automatic mode only if it is secured with isolating protective equipment (e.g. a protective fence). This equipment must comply with EN 14120 and EN 13857!
- In the process, all protective equipment must be in their protective position in automatic mode (e.g. safety doors must be closed, contactless operating protective equipment must be active).

3.4.3 Hazards due to pneumatic energy

Pressurized components of the machine's pneumatic system might pose potential hazards.

WARNING

Risks posed by residual energy in pressurized pneumatic equipment and lines



Unexpected activation of pressurized machine components might pose potential danger. In particular, when pressurizing or depressurizing the system components, hazards may occur due to the unexpected activation of pneumatic actuators.

There are risks of being crushed, sheared, drawn in or caught, and of impact when working on the pneumatic and electrical drives with corresponding peripherals, if these are activated unexpectedly.

The pneumatic system is still under pressure, even if the machine is stopped and switched off.

- Work on the pneumatic systems should be performed only by qualified personnel with special knowledge and experience in pneumatic systems!
- Before working on pressurized systems and assemblies, switch off the compressed air supply at the main valve of the supply and secure the condition! The pressure drop is to be monitored on the manometer!
- Do not open any bolt connections of pneumatic parts as long as the pressure lines are still pressurized! Loosen the connection coupling between the maintenance module and the pneumatic main line. Consider potential remaining energy in the pneumatic actuators!
- Personal protective equipment is to be worn when working at pressurized systems!

WARNING

Risk of injury due to compressed air

When the hose connection becomes loose due to a faulty connection or connector, or if the input pressure gets too high, there is a risk of compressed air escaping from the loose connection or equipment under high pressure. The end of the hose moves uncontrollably and may cause severe eye injuries.

- Never open the system when it is pressurized! Consider potential remaining energy in the pneumatic actuators!
- Check pneumatic hose lines in appropriate intervals for bends and cracks and replace where necessary!

3.4.4 Hazards due to thermal energy

Various hazards due to thermal energy / remaining energy may arise at the machine . The devices remain hot for a short period of time even after shutting down the machine.

WARNING

 **Risk of suffering burn injuries posed by faulty electrical assemblies**

Hot surfaces, splashing away of melted parts in case of electrical assemblies having gone defective, as well as chemical reactions in case of short circuits or overloads may cause burn injuries on the hands and face.



- Remove and replace faulty assemblies only after switching off the power supply and after an adequate cooling period!
- Check the electrical equipment of the machine at regular intervals (inspection every 4 years in accordance with the DGUV V3)! Replace singed or scorched cables! Inspect insulation of all moving cables for damage at regular intervals during repair and maintenance works! Eliminate loose connections!

WARNING

 **Risk of burns due to contact with hot surfaces of drives and electrical equipment in the electrical switch box**

There is a risk of suffering burn injuries posed by coming into contact with hot surfaces, equipment in the electrical switch box



- Keep a safe distance from hot surfaces! Pay attention to warning symbols on devices! Wear protective clothing!
- Never touch any machine components that are hot as a result of overheating! Plan for an adequate cooling period!

3.4.5 Hazards due to emissions



Potential danger at the machine is caused by various kinds of emission.

3.4.5.1 Sound (Noise)

Depending on the ambient conditions at the installation site of the machine, a higher or lower sound pressure level can be achieved (refer to Technical Specifications ► 4.1.2).

The continuous sound pressure level and sound output level emitted by the machine are specified in the acceptance report that is included in the Appendix of this Installation Manual.

WARNING

Hazards due to noise

There is a hazard of hearing loss or health impairment resulting from the continuous sound pressure level produced by the machine. Depending on ambient conditions and the application, a higher sound pressure level may develop.

- For noise levels above 80 dB(A) it is recommended to wear suitable protective ear muffs while operating the machine !
- For noise levels above 85 dB(A) at the machine, you must wear suitable ear muffs!
- The sound pressure level must be monitored by the operator, who must take appropriate protective measures as required!



3.4.6 Hazards due to operating materials

For cleaning and lubricating as well as when carrying out work for maintaining and servicing the machine, sometimes chemical substances and operating materials are used, which may be harmful for the health of the persons working on the machine if they are not used properly.

3.4.6.1 Risks posed by cleaning agents

To clean the machine use a cold cleaner having a high flash point if possible. In this connection, pay attention to the product information given in the enclosed leaflet/on the label of the cleaning agent or the associated safety instructions on the safety data sheet for using the cleaning agent.

WARNING



Risk of fire or explosion posed by using easily inflammable and/or combustible cleaning agents





When using benzine as the cleaning agent or for servicing the machine there is an increased risk of fire or explosion. Benzine forms a highly explosive gas-air mixture even at room temperature by benzine vapors escaping. This may result in burn injuries or other risks to health as well as damage to property.

- Fire, open flames and smoking in the vicinity of the machine are prohibited at all times!
- Do not use benzine as cleaning agent under any circumstances whatsoever! For cleaning and servicing the machine, you must use a cold cleaner with a high flash point!
- Combustible liquids may never be stored within the danger zone of the machine !

3.4.6.2 Hazards due to lubricants

To lubricate the gear unit of the drive unit of the machine, if necessary, you may use lubricants that may lead to impairment of health if they are not used properly.

WARNING

Risk posed by the lubricant coming into contact with the skin or mucous membranes

Continuous contact with the lubricants used near the machine may lead to damage to the skin, mucous membranes or to other impairments to health.

- In case of contact with the eyes, rinse out thoroughly and immediately using plenty of water and consult a doctor.
- In case of skin irritations, immediately rinse the affected area with water and wash it with soap!
- Always wash hands thoroughly with soap after working with the lubricant!
- Observe and follow the instructions in this Installation Manual as well as the safety data sheet of the lubricant used!
- Comply with the safety regulations and use the protective equipment prescribed!

4

Design and Function

4 Design and Function

In this section, you will become familiarized with the machine . It contains an overview of the machine and its most important components, parts and safeguards. The functions of the components and the safety and protective equipment are described. You will also receive information on the most important technical data.

4.1 General Overview

The machine »Stand-alone changing system for electrode caps« is used for automatic changing of electrode caps made from copper materials on the moving welding gun.

In the process, machining is always done in pairs. To carry out the process steps, the welding gun is fed to the machine, with this being done by an industrial robot in most cases. It is installed on a machine base.

The machine consists of an electrode cap changing system, which removes worn electrode caps from the welding gun with the help of a rotary movement. In the case of the »H« setup type, the electrode caps fall into a collecting box. With the »V2« setup type, the electrode caps are fed with the help of an extraction system to a collection bag. Depending on the design, the machines may have one or two electrode cap changing systems.

After the worn electrode caps have been removed, the welding gun is fed to the electrode cap cartridge to pick up new electrode caps. They are pressed on the electrode cap pressing plate by closing the welding gun to ensure proper fit on the gun.

The electrode cap cartridge is designed as a quick-change cap cartridge. It can be fitted with electrode caps outside the welding cell and changed in a few simple steps.

The electrode cap changing system is moved with the help of a drive, with the transfer taking place via a gear unit. The entire electric and pneumatic control system up to the interface to the entire system is installed in an electrical switch box.

4.1.1 Overall diagram – Overview

The machine is manufactured in two setup types depending on the gear unit design:

- Setup type »H« with horizontally arranged gear unit and
- Setup type »V2« with vertically arranged gear unit and with cap extraction unit.

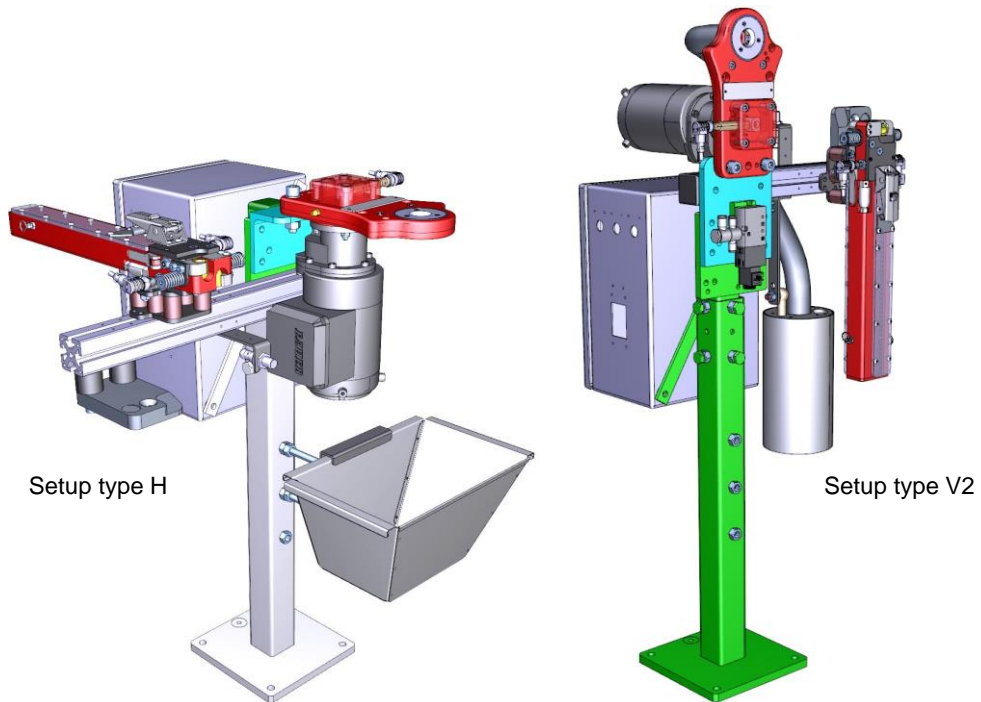

Stand-alone changing system – Setup types of the BWS 5700

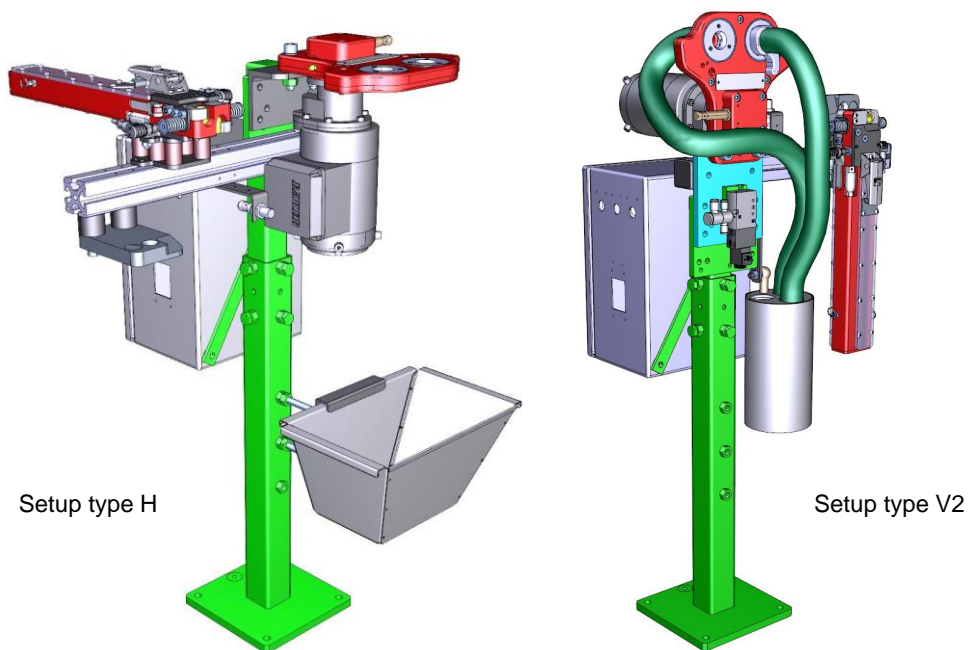

Stand-alone changing system – Setup types of the BWS 5710

4.1.2 Technical Specifications

Parameter	Values / Designation			
Operating voltage	220 VY	400 VY	600 VY	600 VY
Control voltage	24 V	24 V	24 V	24 V
Motor nominal current	0,56 A	0,30 A	0,20 A	0,205 A
Motor nominal speed (no-load)	27 rpm	23 rpm	23 rpm	27 rpm
Changing head speed (no-load)	17 rpm	15 rpm	15 rpm	17 rpm
Frequency	60 Hz	50 Hz	50 Hz	60 Hz
Permissible voltage fluctuations	±5%	±5%	±5%	±5%
Power / On time	0,06 kW – S1			
Fuse	16 A	16 A	16 A	16 A
Number of phases	3/N/PE	3/N/PE	3/N/PE	3/N/PE
Type of power connection	Fixed connection			
Airborne sound	< 73 dBA			
Compressed-air connection	4-6 bar (oil-free)			
Air consumption (only for setup type »V2«)	at 6 bar approx. 545 l/min.			
Weight	approx. 40 kg (depending on the design, without packaging material)			
Base	Suitable machine hall floor			
Electromagnetic compatibility	No electromagnetic radiation present			

4.2 Safety devices

The necessary safety while working on the machine is achieved by multiple safety devices:

- fixed isolating protective devices,
- installation of hazardous moving machine components in encapsulated housings,
- accommodating live parts in housings provided for this purpose.

WARNING	
	<p>Danger due to improper condition of the machine</p> <p>There are hazards at the machine resulting from faults or malfunctions of the safety equipment.</p> <ul style="list-style-type: none">• If they are not in proper condition: Do not switch on the machine and secure it against being put into operation inadvertently!• Check the proper working condition of the safety devices, the feed lines and the overall condition of the machine once per shift!• Safety devices and equipment must be checked for their proper function and be cleaned! The intervals are to be defined by the safety officer in accordance with the manufacturer's instructions!

4.2.1 Protective casings

The moving components of the gear unit of the drive unit are secured against direct intervention by housing covers.

4.3 Pneumatic devices

The connection of the compressed air supply to the pneumatic devices of the machine takes place considering the technical specifications (Connection ► Chapter 4.1.2) directly on the solenoid valve.

NOTICE



Pneumatic diagram

Detailed information on the pneumatic connection is provided in the connection and switching diagram (Pneumatic plan)! This is given in the Appendix to this Installation Manual.

- The company operating the machine must ensure that the input pressure lies **between 4 and 6 bar** (only applies to the electrode cap extraction unit). A lower or higher input pressure may restrict the functionality and lead to the personnel being endangered.

WARNING



Danger of injury from pneumatic energy

Basically, there are risks (collision, crushing and shearing) near the pneumatically driven components of the machine while putting it into operation, while doing maintenance and cleaning work as well as during troubleshooting and fault rectification.



When aerating and de-aerating pneumatic parts, unforeseen movements of pneumatic actuators may result in hazards.

- Works at the pneumatic system may be carried out only by qualified and authorized personnel!
- Wear personal protective equipment!
- Switch the machine off before starting to work at the pneumatic equipment! Turn the main shutoff valve of the service unit to "OFF" and secure it with a padlock!
- Do not open any pneumatic connections as long as the pneumatic system is still pressurized!
- Disconnect the connection coupling between the service unit and the pneumatic main line!
- Examine all pneumatic hoses for signs of aging and damage in the course of maintenance work and replace them if necessary!

4.4 Electrical equipment



There are various electrical assemblies and components installed on the machine.

All electrical devices are marked with the warning sign » Warning - Dangerous voltage« and therefore require particular caution.

The machine is primarily equipped with the following electrical components:

- Electrical switch box with electrical power supply isolating switch (optional), ► Chapter 4.4.1
- Drive unit (Geared motor), ► Chapter 4.5.3
- Sensor system, ► Chapter 4.4.2

DANGER



Danger to life and damage to electric assemblies due to static electricity discharge

There is basically a hazard arising from freely accessible electrical assemblies in the electrical switch box, which can discharge their static electricity.

The main feed terminals are energized, even if the main switch is turned off.

- Works at the electric devices may be performed by qualified personnel only!
- Keep the electrical switch box locked at all times!
- The specialists must discharge their static electricity before opening the electrical switch box door!
- Disconnect the mains plug to attain complete zero potential!

NOTICE



Circuit diagram with connections

Detailed information as well as specifications for the connections in the electrical switch box are provided in the circuit diagram in the Appendix of the Installation Manual (refer to ► Chapter 11.5).

4.4.1 Electrical switch box

The lockable electrical switch box is located on the basic plate of the basic leg stand, where it is mounted to the machine. The electrical switch box of the machine houses the power supply and other electrical assemblies in addition to the electrical line disconnecter.

- Switching contactor,
- Motor protection for the drive of the electrode cap changing system,
- Terminal strip,
- Plug-in connections (Electrical connection),
- Cable entries.



Electrical switch box of the machine – Mechanical design

- | | | | |
|---|---|---|---|
| 1 | Locking mechanism | 3 | Connection bushing of power supply (optional) |
| 2 | Electrical line disconnecter (optional) | | |

The door of the electrical switch box is equipped a special locking mechanism in order to protect against unauthorized access to exposed and live cables as well as electrical components in the electrical switch box of the machine. The locking mechanism can be opened and locked only with a special key.

4.4.1.1 Connection bushing of the power supply

The machine is connected to the operator's power supply with the help of a terminal strip in the electrical switch box by default.

Alternatively, the connection bushing (optional) is located on the outside of the electrical switch box for the power supply.

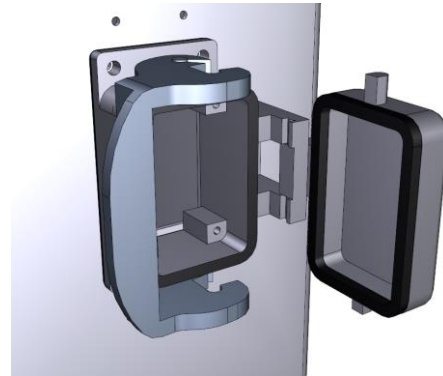

4.4.1.2 Motor circuit breaker

The motor circuit breaker in the electrical switch box is coupled with the optional line disconnecter, which, when tripped, also switches (off) the line disconnecter to the position »0« (Off).

If the optional line disconnecter is not available, authorized personnel must open the electrical switch box and switch off the motor circuit breaker directly in the cabinet.



4.4.2 Sensor system

The machine has various signal encoders provided by the manufacturer (inductive proximity switches) in order to ensure the functionality as well as to monitor the operation.

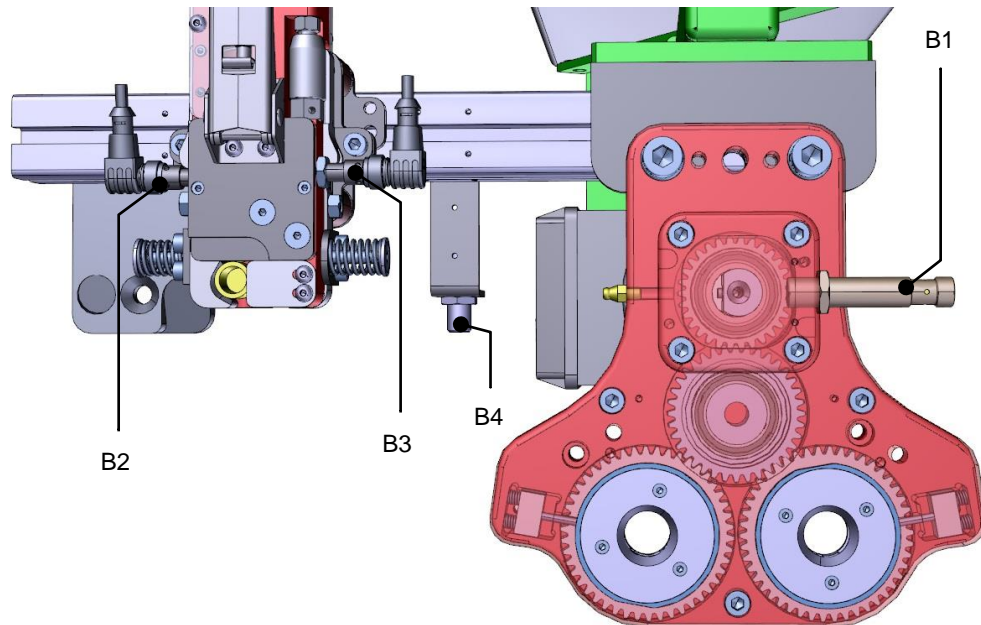

Sensor system – installed limit switches (sample and simplified representation in top view form)

Proximity switch	Monitored function / Monitored status
B1	<p>Checking the revolution of the gearbox motor</p> <ul style="list-style-type: none"> • Sensor for monitoring the revolution of the gearbox motor • 0/1 signal per revolution of the gearbox motor
B2/B3	<p>Fill level monitoring of the electrode cap cartridge</p> <ul style="list-style-type: none"> • Sensor for monitoring the fill level in the electrode cap cartridge • Signal 1: Electrode caps available • Signal 0: no electrode caps available at sensor level • At the time point of changing over from »1« to »0«, there are still 3 electrode caps in the electrode cap cartridge
B4	<p>Electrode caps checking (Presence)</p> <ul style="list-style-type: none"> • Sensor for monitoring the extraction of the electrode cap and its positioning <p>Electrode cap extraction</p> <ul style="list-style-type: none"> • After extracting out the old electrode cap, the welding gun must be moved with the shaft a short distance past the sensor B4. • Signal »0« – i.e. the electrode cap has been extracted successfully. • Signal »1« – i. e. error message – STOP! The electrode cap has possibly not been extracted.

Proximity switch	Monitored function / Monitored status
	<p data-bbox="544 338 842 371">Electrode cap positioning</p> <ul data-bbox="544 376 1331 598" style="list-style-type: none"><li data-bbox="544 376 1305 434">• After pressing on the new electrode cap, the welding gun must be moved with the shaft a short distance past the sensor.<li data-bbox="544 439 1321 497">• Signal »1«– i.e. the electrode cap has been pressed on successfully.<li data-bbox="544 501 1331 598">• Signal »0«– i. e. error message – STOP! The electrode cap has possibly not been pressed on properly or it has not been pressed on at all.

4.5 Mechanical design

The machine »Stand-alone changing system for electrode caps« primarily consists of:

- Electrode cap cartridge, ► Chapter 4.5.6
- Electrode cap changing system, ► Chapter 4.5.4
- Electrode cap pressing plate, ► Chapter 4.5.9
- Electrode cap collecting box or electrode cap extraction unit with solenoid valve, ► Chapter 4.5.7 and 4.5.5
- Drive for the gear unit, ► Chapter 4.5.3
- Gear unit, ► Chapter 4.5.4
- Electrical switch box, ► Chapter 4.4.1
- Basic leg stand, ► Chapter 4.5.8

NOTICE



Order-specific equipment of the machine in accordance with the customized configuration

This Installation Manual describes the machine »Stand-alone changing system for electrode caps«.

The design (1-way or 2-way changing head), fittings (optional assemblies*) and installation position (»H« or »V« setup type) of the supplied machine matches the configuration at the customer's end.

The following chapters of this Installation Manual describe the series configuration of the machine as well as the optional equipment and setup types. The individual assemblies (changing system, extraction, etc.) are basically identical in their construction and function – only the arrangement at the basic leg stand may vary.

The figures used in the following chapters represent the BWS 5710 and the mechanical design and construction of the machine by way of examples.

*Optional fittings are marked in this Installation Manual accordingly with the supplement »Optional fitting«.

4.5.1 Mechanical design of the BWS 5710

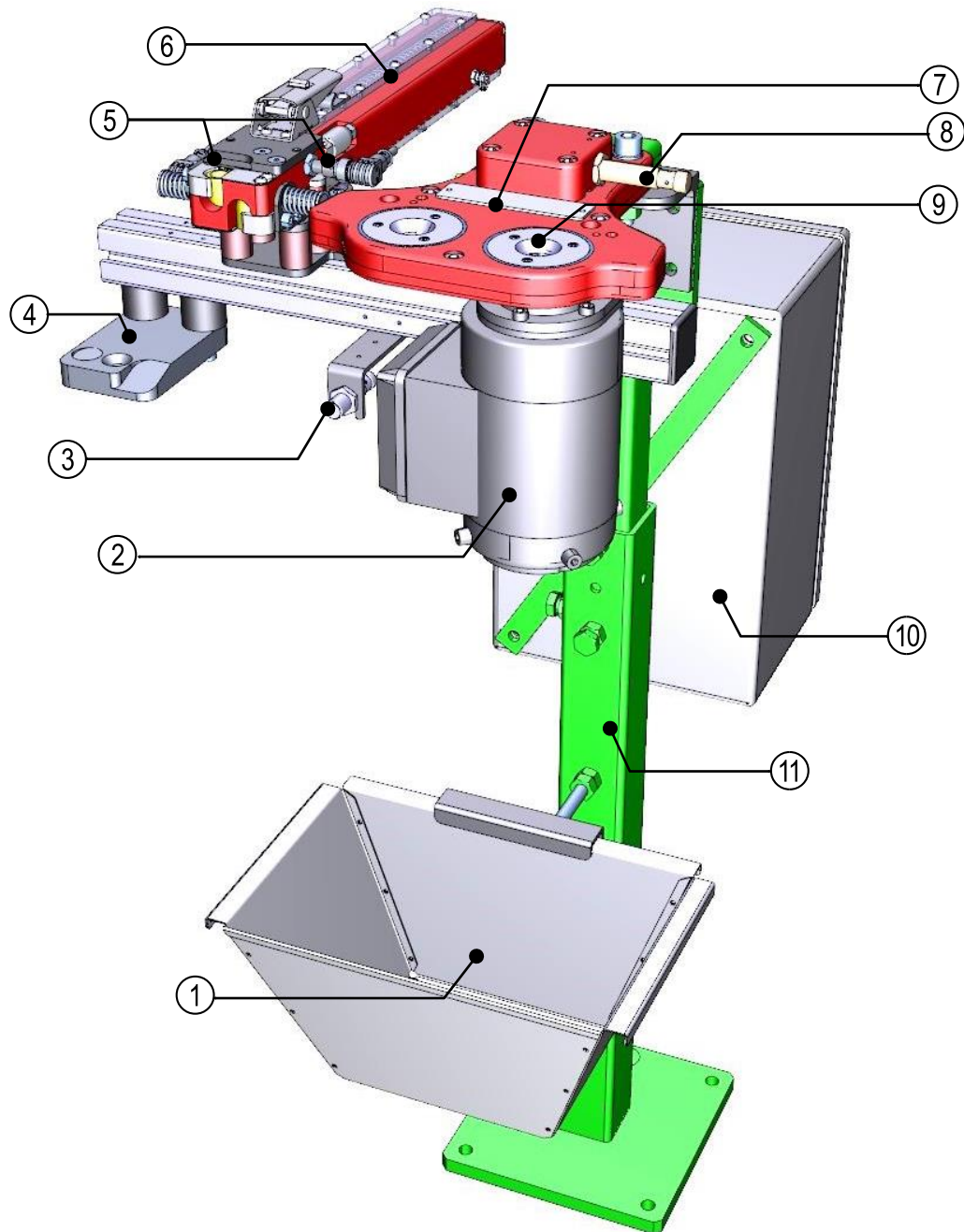

Stand-alone changing system for electrode caps (BWS 5710 Setup type H)

- | | | | |
|---|---|----|--|
| 1 | Electrode cap collecting box | 6 | Electrode cap cartridge |
| 2 | Gearbox motor | 7 | Gear unit |
| 3 | Sensor »B4« - »Query electrode cap extracted/pressed on« | 8 | Sensor »B1« - »Checking the revolution of the gearbox motor« |
| 4 | Pressing plate (Pressing the electrode cap on) | 9 | Electrode cap changing system |
| 5 | Sensor »B2/B3« - »Fill level monitoring of the electrode cap cartridge« | 10 | Electrical switch box |
| | | 11 | Basic leg stand (height-adjustable) |

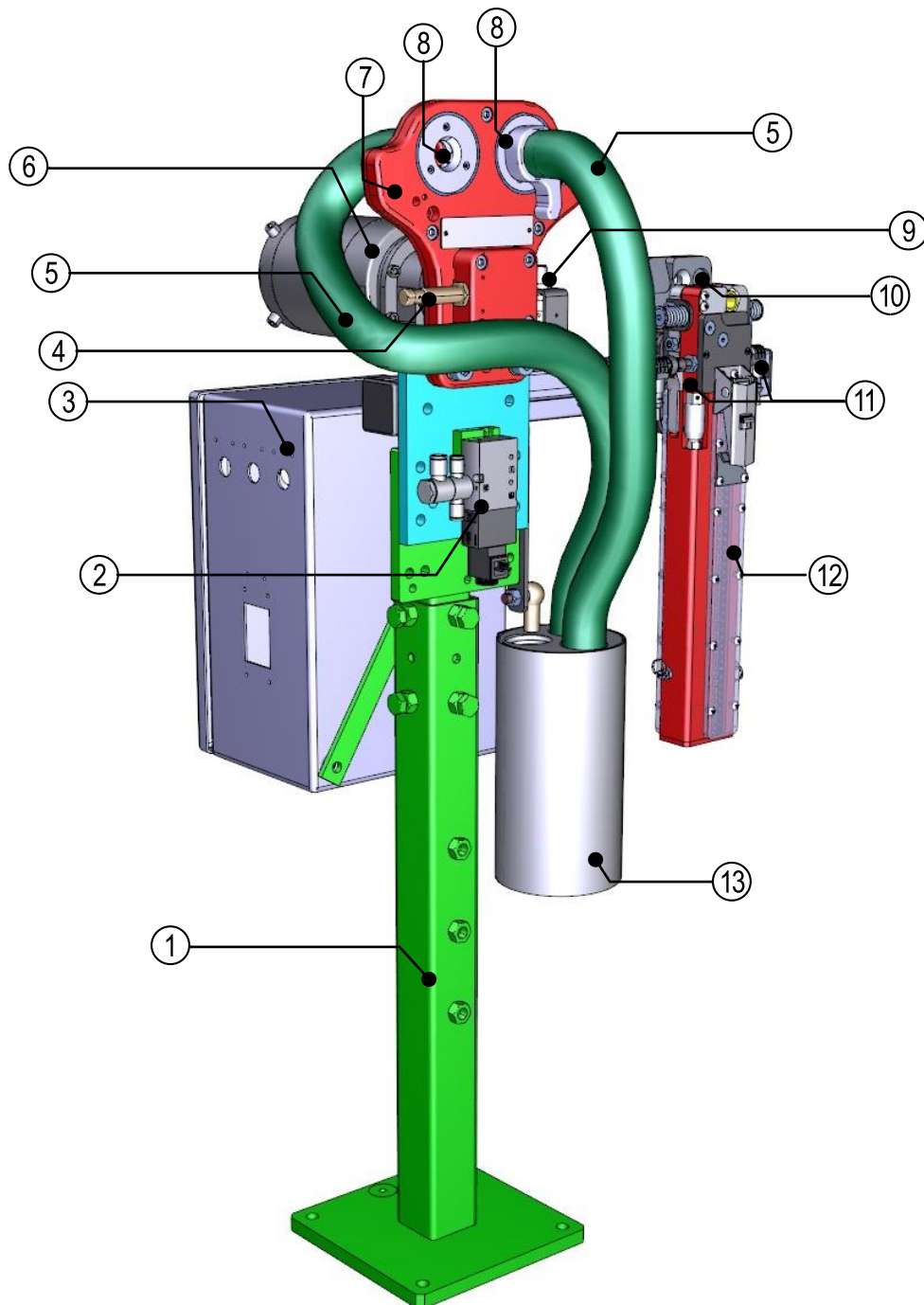

Stand-alone changing system for electrode caps (BWS 5710 Setup type V2)

- | | | | |
|---|--|----|---|
| 1 | Basic leg stand (height-adjustable) | 8 | Electrode cap changing system |
| 2 | Solenoid valves »Electrode cap extraction unit« | 9 | Sensor »B4« - »Query electrode cap extracted/pressed on« |
| 3 | Electrical switch box | 10 | Pressing plate (Pressing the electrode cap on) |
| 4 | Sensor »B1« - »Checking the revolution of the gearbox motor« | 11 | Sensor »B2/B3« - »Fill level monitoring of the electrode cap cartridge« |
| 5 | Electrode cap extraction unit | 12 | Electrode cap cartridge |
| 6 | Gearbox motor | 13 | Collection bag |
| 7 | Gear unit | | |

4.5.2 Mechanical design of the BWS 5700

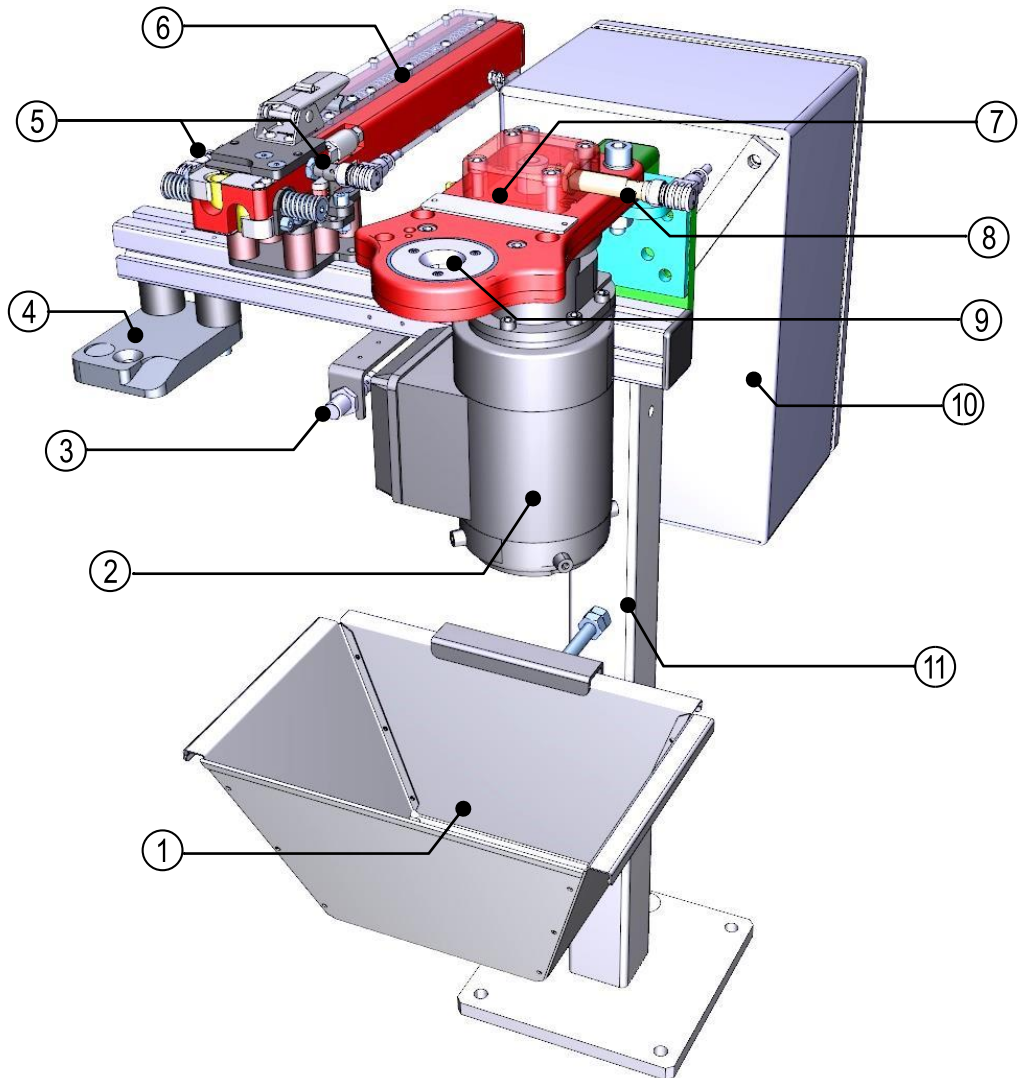

Stand-alone changing system for electrode caps (BWS 5700 Setup type H)

- | | | | |
|---|---|----|--|
| 1 | Electrode cap collecting box | 6 | Electrode cap cartridge |
| 2 | Gearbox motor | 7 | Gear unit |
| 3 | Sensor »B4« - »Query electrode cap extracted/pressed on« | 8 | Sensor »B1« - »Checking the revolution of the gearbox motor« |
| 4 | Pressing plate (Pressing the electrode cap on) | 9 | Electrode cap changing system |
| 5 | Sensor »B2/B3« - »Fill level monitoring of the electrode cap cartridge« | 10 | Electrical switch box |
| | | 11 | Basic leg stand (height-adjustable) |

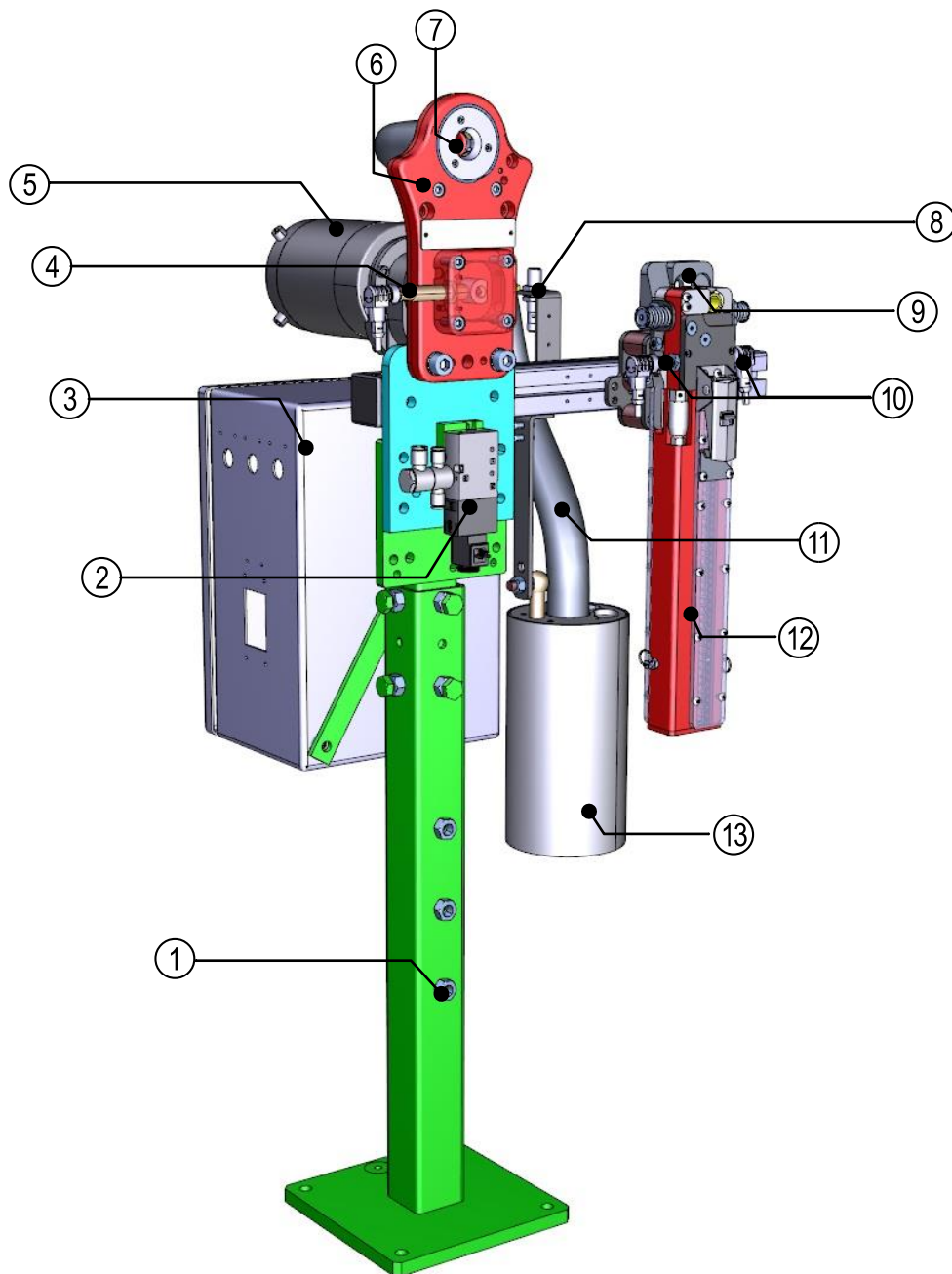

Stand-alone changing system for electrode caps (BWS 5700 Setup type V2)

- | | | | |
|---|--|----|---|
| 1 | Basic leg stand (height-adjustable) | 8 | Sensor »B4« – »Query electrode cap extracted/pressed on« |
| 2 | Solenoid valves »Electrode cap extraction unit« | 9 | Pressing plate (Pressing the electrode cap on) |
| 3 | Electrical switch box | 10 | Sensor »B2/B3« – »Fill level monitoring of the electrode cap cartridge« |
| 4 | Sensor »B1« – »Checking the revolution of the gearbox motor« | 11 | Electrode cap extraction unit |
| 5 | Gearbox motor | 12 | Electrode cap cartridge |
| 6 | Gear unit | 13 | Collection bag |
| 7 | Electrode cap changing system | | |

4.5.3 Gearbox motor

The electrical motor, with special adapter for transmitting power to the gear wheel drive, can be operated in various voltage ranges and also in reversing mode (electrode cap changing system) (refer to Technical Specifications in ► Chapter 4.1.2). The electrical motor is designed with a terminal box.

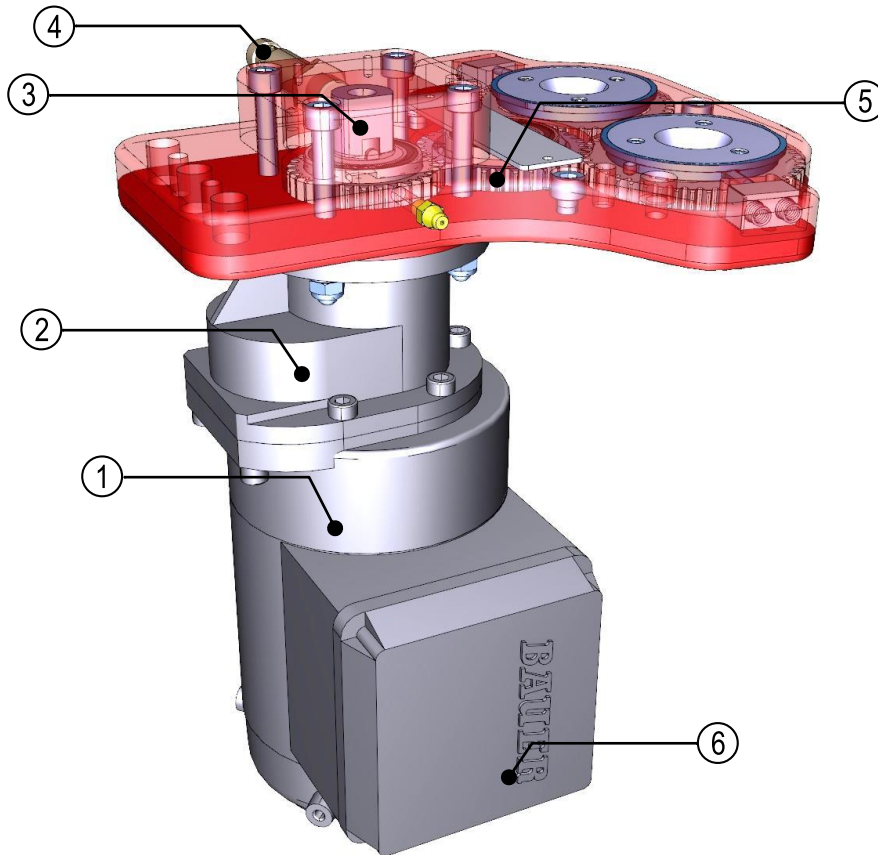

Electrical motor – Mechanical design (simplified display)

- | | | | |
|---|--|---|--------------------------------------|
| 1 | Electrical motor | 5 | Gearbox unit |
| 2 | Special adapter | 6 | Terminal box of the electrical motor |
| 3 | Drive shaft | | |
| 4 | Sensor »B1« – Checking the revolution of the gearbox motor | | |

NOTICE



Observe and follow the suppliers' documentation

In addition, the manufacturer's specifications of the gearbox motor in the suppliers' documentation must be observed and followed!

- An overview of the supplier documentation is provided in ► Chapter **Fehler! Verweisquelle konnte nicht gefunden werden..**

4.5.4 Gearbox unit

The gear unit transfers the rotary movement of the drive unit to the changing head(s) of the machine. Proximity switches installed make signals available for external evaluation.

The changing heads rotate in opposite directions. With one changing head each, the upper or lower cap is extracted from the shaft.

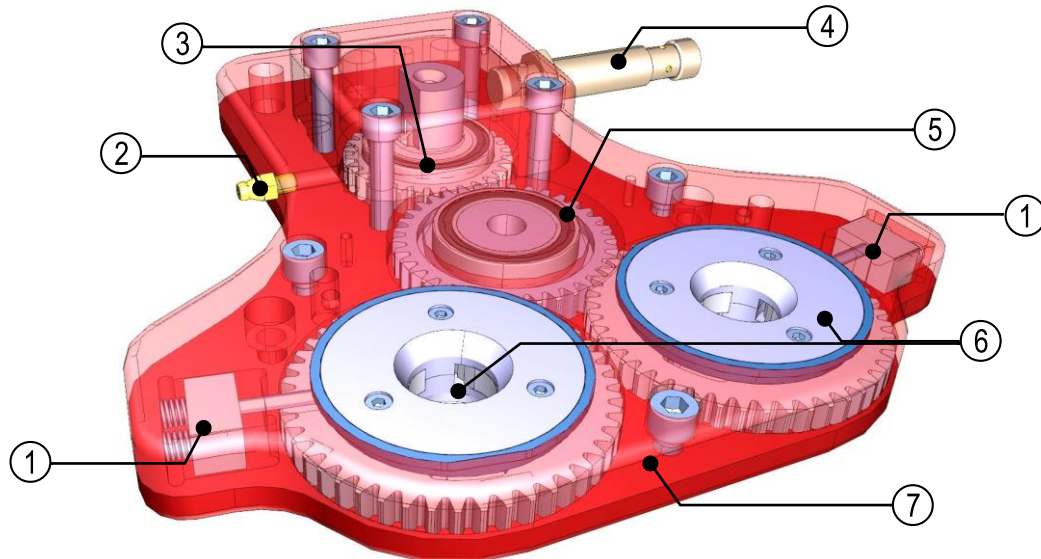

Gearbox unit – Mechanical design (simplified representation)

- | | | | |
|---|--|---|---|
| 1 | Relative brake | 5 | Gear wheel |
| 2 | Lubrication zirc »Gear unit« | 6 | Changing head on the carrier gear wheel |
| 3 | Drive gear wheel on drive shaft | 7 | »Bottom« plate |
| 4 | Sensor »B1« – Checking the revolution of the gearbox motor | | |

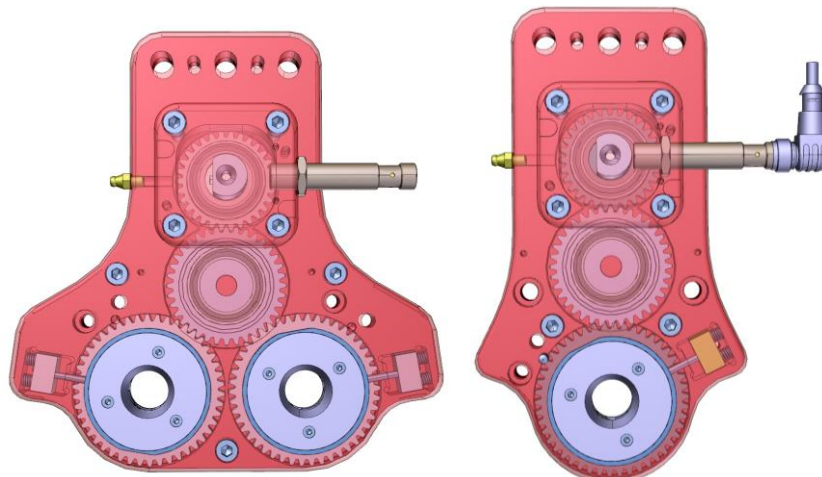

Gearbox unit – Variation in top view: left: BWS 5710; right: BWS 5700

4.5.5 Electrode cap extraction unit (Setup type V2)

machines in the vertical installation position »V2«, are designed instead of an electrode cap collecting box (► Chapter 4.5.7) with a pneumatically driven electrode cap extraction unit. The electrode caps extracted from the welding gun is extracted from the changing head(s) of the cap changer tool in a controlled manner.

The electrode cap extraction unit consists of an extraction nozzle, an extraction hose with collection bag and the solenoid valve.

The extraction has to be activated only after opening the changing head. The solenoid valve switches the compressed air for the extraction operation accordingly. The collection bag must be emptied regularly in the course of maintenance and cleaning work and can be reused.

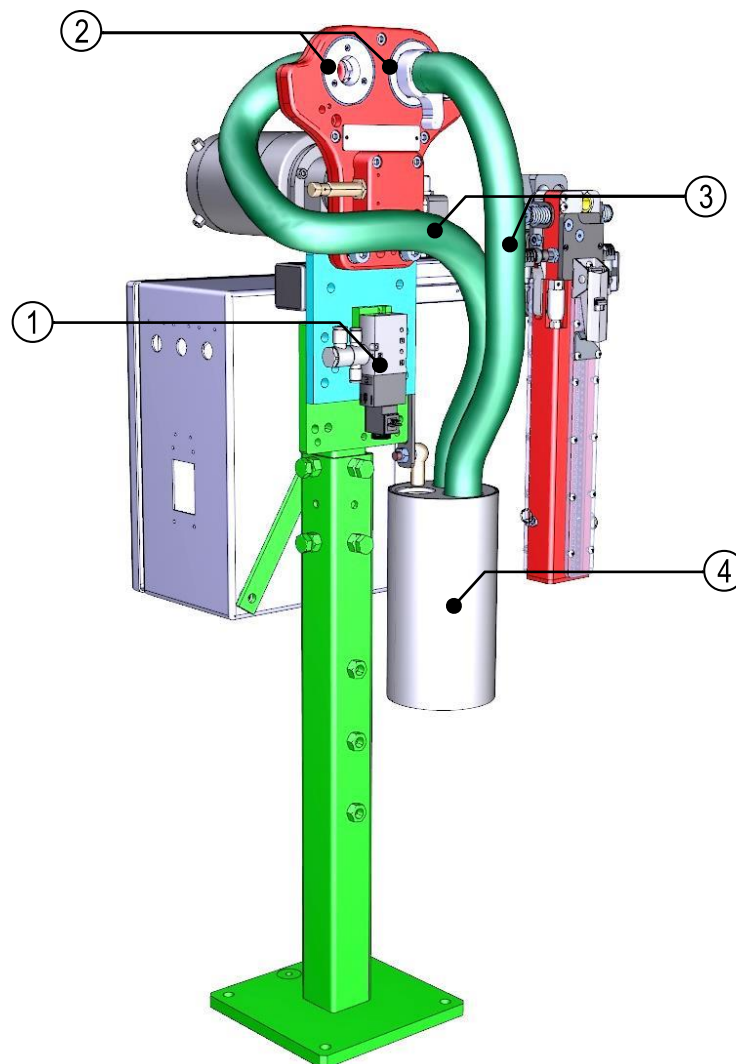

Electrode cap extraction unit on the machine in the installation position »V2« – Mechanical design

- | | |
|---------------------------------|-------------------|
| 1 Solenoid valve | 3 Extraction hose |
| 2 Electrode cap changing system | 4 Collection bag |

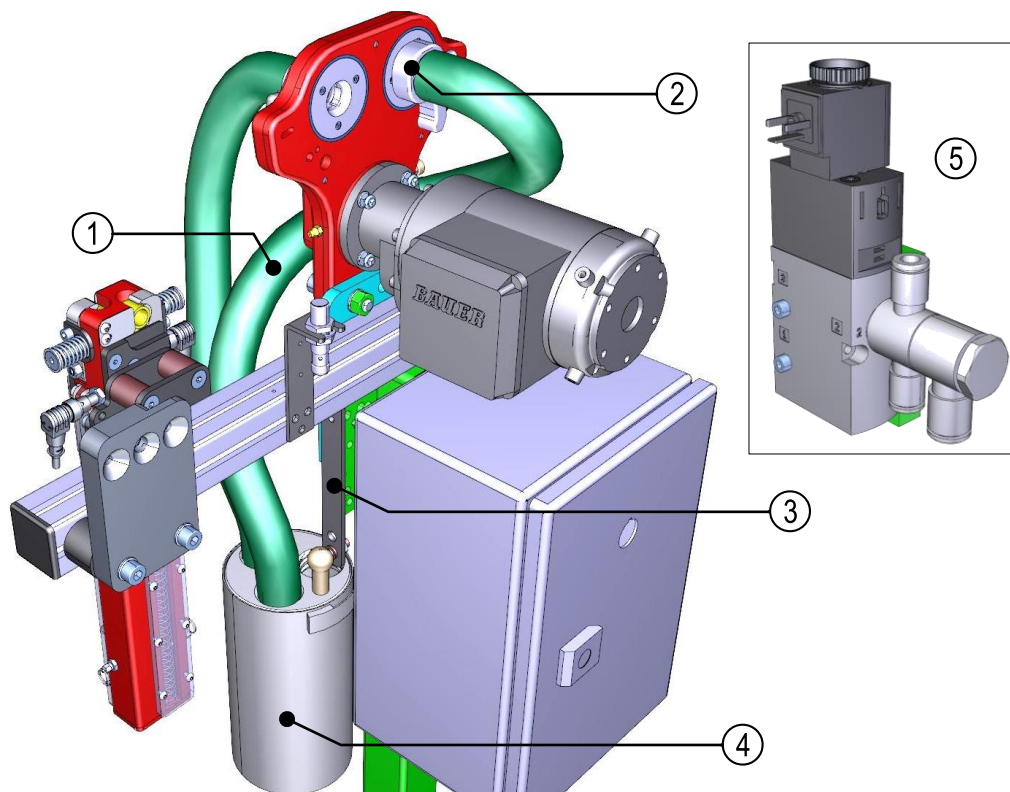

Electrode cap extraction unit on the machine in the installation position »V2« – Mechanical design

- | | | | |
|---|--|---|----------------|
| 1 | Extraction hose | 4 | Collection bag |
| 2 | Extraction nozzle with compressed air connection | 5 | Solenoid valve |
| 3 | Collection bag holder | | |

4.5.6 Electrode cap cartridge

The electrodes cap cartridge is designed as a quick-change system and consists of a changing cartridge with two shafts, which contain the electrode caps, as well as the cartridge head, which ensures the pickup of the electrode caps by the welding gun.

The cartridge head is installed permanently to the mounting adapter of the machine. The changing cartridge is connected permanently with the cartridge head with the help of a tension lock with safety clip. To refill the electrode cap cartridge, only the changing cartridge must be extracted.

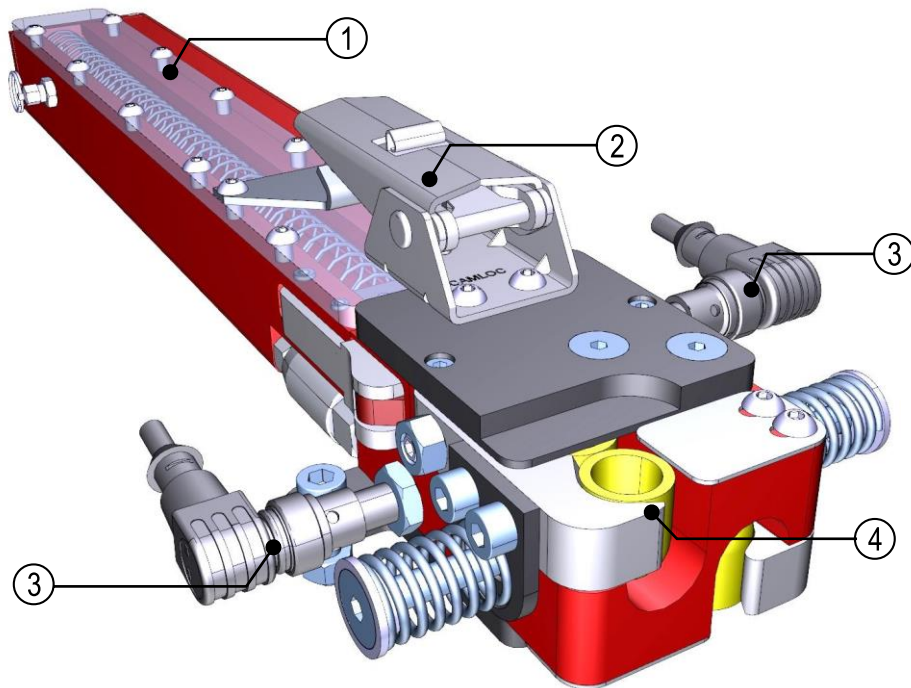

Electrode cap cartridge – Mechanical design

- | | | | |
|---|----------------------------------|---|--------------------------------|
| 1 | Changing cartridge with 2 shafts | 3 | Sensor »Fill level monitoring« |
| 2 | Tension lock with safety clip | 4 | Cartridge head |

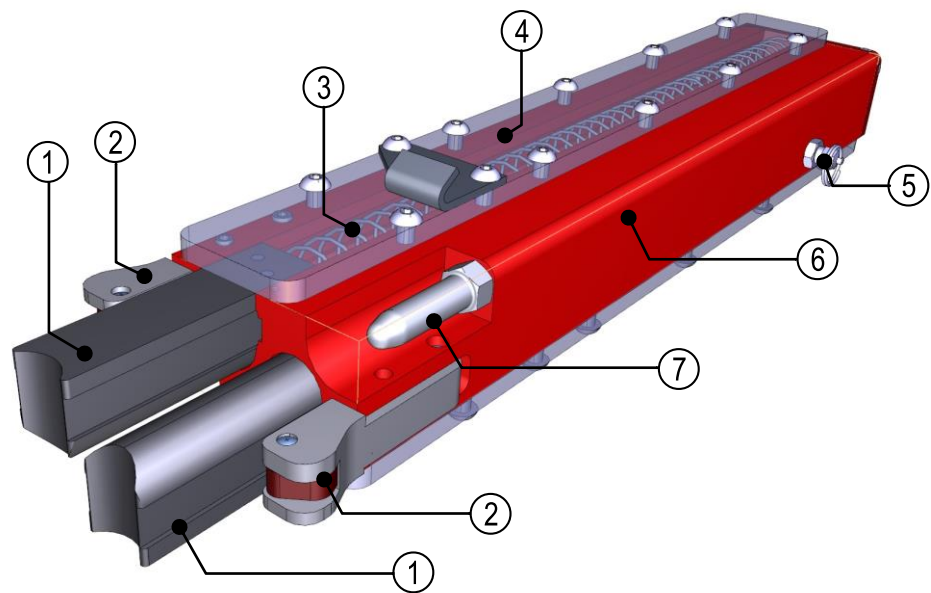

Electrode cap cartridge – Changing cartridge

- | | |
|--|--------------------------------|
| 1 Pressure piece with compressing spring | 5 Locking pin (optional) |
| 2 Locking lever | 6 Changing cartridge base body |
| 3 Compressing spring | 7 Centering bolt |
| 4 Sealing plate | |

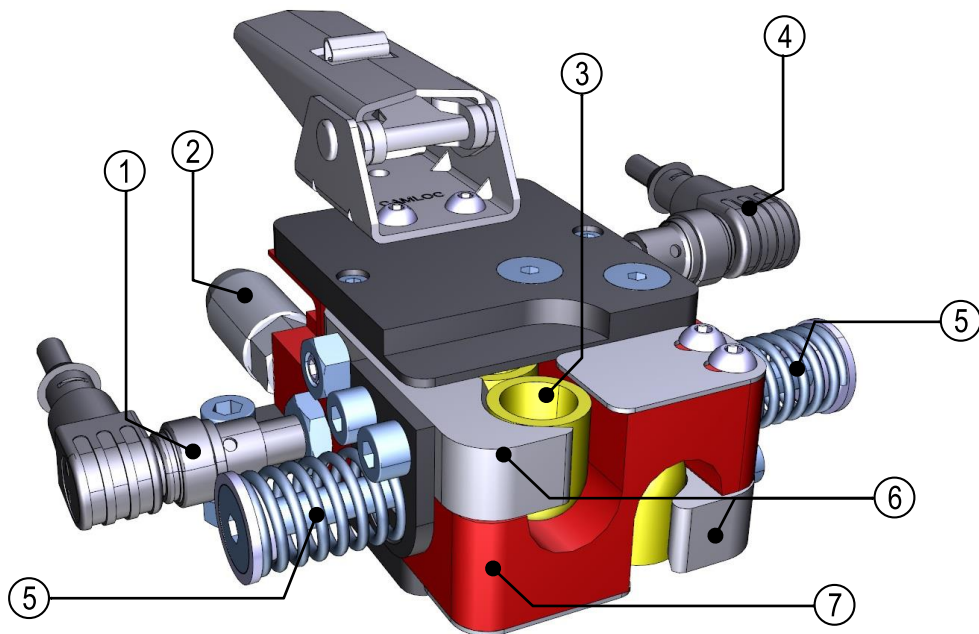

Electrode cap cartridge – Cartridge head

- | | |
|--|---|
| 1 Sensor »Fill level cartridge shaft above« | 4 Sensor »Fill level cartridge shaft below« |
| 2 Centering bushing (for centering bolt of the changing cartridge) | 5 Compressing spring (Separation) |
| 3 Electrode cap in the removal position | 6 Cartridge extraction |
| | 7 Changing cartridge base body |

4.5.7 Electrode cap collecting box (Setup type H)

No electrode cap extraction unit is provided for the setup type H of the machine. The electrode cap changing system is open downwards so that the electrode caps fall into the trapeze-shaped electrode cap container. The electrode cap container is kept in place by a holding bracket (U-shaped profile), which is mounted on the basic leg stand.



Electrode cap collecting box

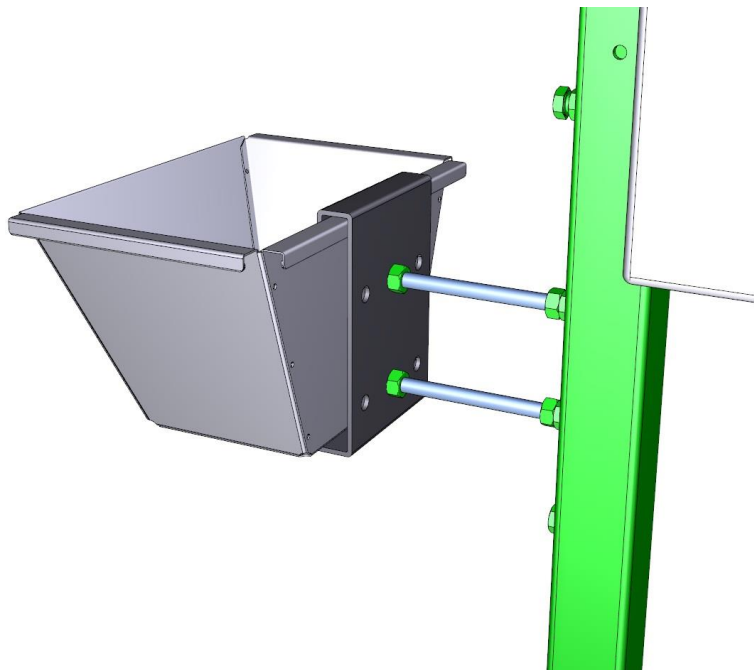

Electrode cap collecting box – Fastening to the basic leg stand

4.5.8 Basic leg stand with height adjustment mechanism

The basic leg stand is used to mount and fasten the components (among others, electrical switch box, electrode collecting box, gear unit, etc.) of the machine. With the help of the height adjustment mechanism, you can adjust and fix the correct working height of changing system for electrode caps (see ► Chapter 5.4.5).

To install the machine, the basic leg stand must be anchored with appropriate fasteners to the floor (see ► Chapter 5.4.4). In addition, there are bore holes in the basic plate to be able to lay the potential equalization.

The height adjustment mechanism with the adapter plate for installing the machine components can be adjusted on the square hollow profile accordingly to the desired working height.

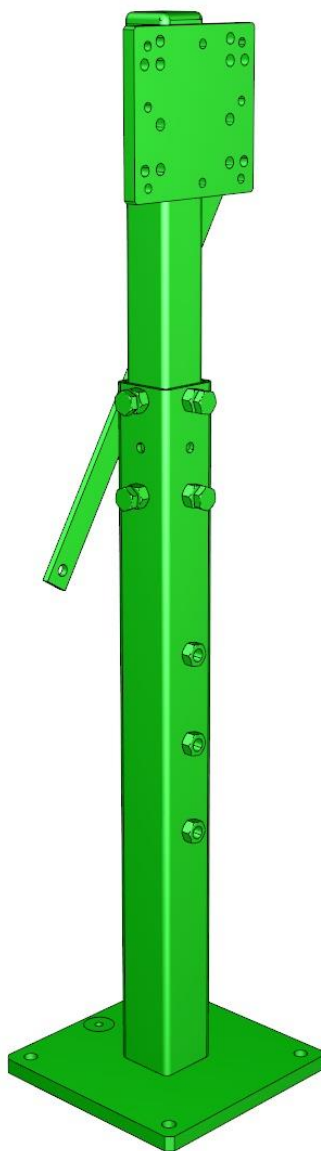

Basic leg stand

4.5.9 Electrode cap pressing plate

After a new electrode cap has been picked up from the welding gun on the electrode cap cartridge, it must be pressed down on the cone of the shaft of the welding gun. To begin with, the robot moves with the welding gun to the sensor »B4« (electrode cap inspection), to check for the presence of an electrode cap at the shaft of the welding gun.

To ensure proper fit on the shaft of the welding gun, the electrode cap is pressed on the electrode cap pressing plate by closing the welding gun with nominal force.

Detailed information for programming the integration of the electrode cap pressing plate is provided in ► Chapter 4.6.3.

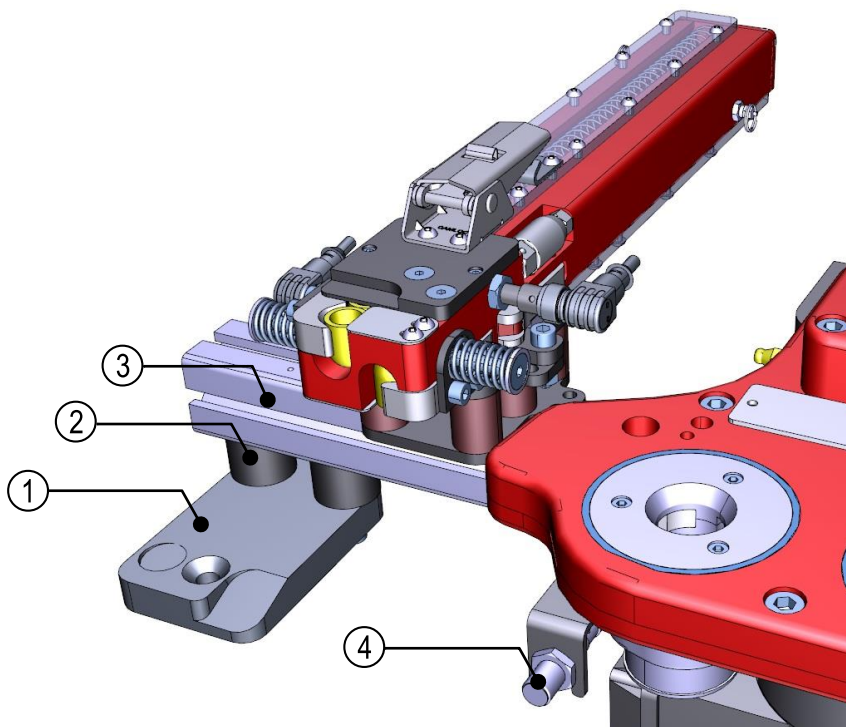

Electrode cap pressing plate – Mechanical design

- | | | | |
|---|------------------------------|---|----------------|
| 1 | Electrode cap pressing plate | 3 | Profile holder |
| 2 | Rubber-metal buffer | 4 | Sensor »B4« |

4.6 Functional procedure for »Electrode cap change«

This Chapter aims to explain the functional procedure to the operating personnel while changing the electrode caps of welding gun as well as to highlight the circumstances to which special attention needs to be paid before starting the change operation.

IMPORTANT



Information on electrode cap change with the BWS 5700

- Electrode caps are changed one after another in the changing head.
- Use the machine only when the shafts of the welding gun are plugged in.



Information on electrode cap change with the BWS 5710



- Electrode caps are changed one after another. The operation must be repeated accordingly, but by using the second changing head. However, the functional procedure for changing both electrode caps is identical.

Pre-requisites for electrode cap change:

- Before electrode cap change, the supply of power and cooling water to the welding gun must be interrupted (cooling water extraction)!
- The electrode cap cartridge must be filled for the first time
- The electrode cap must be in removal position
- The changing head is opened
- The electrode cap collecting box has been hung up or the electrode cap suction unit is running

4.6.1 Safety instructions »Electrode cap change«

CAUTION

Risk of injury by electrode caps that are thrown out (electrode cap extraction unit for Setup type »V2«)

There is the risk of injury (eyes) if the hose of the electrode cap extraction unit is not installed or if it is not installed properly on the extraction nozzle at the changing head, which means that electrode caps could get thrown out by the extraction operation.

- Before carrying out any work of fault rectification, interrupt the supply of compressed air, as well as the electricity supply to the machine, by putting off the main switch and pulling out the power supply connector!
- Do not disassemble the extraction hose of the electrode cap extraction unit! Operating the machine is permitted only with completely installed and damage-free extraction hose!
- Inspect the connection and extraction hose at regular intervals of time for tight fit and for damage!
- After completing work, the electrode cap extraction unit must be assembled again completely!
- Wear protective clothing (gloves, shoes, safety goggles, face masks)!

WARNING**Risk of injury as well as risk of damage to property by the machine starting up automatically when rectifying faults**

When using metallic tools while working (maintenance, fault rectification) on the changing head there is the risk of injury as well as the risk of damaging the machine, if the changing head starts up undesirably during fault rectification. The tool could get destroyed and broken pieces may get thrown out. The tool gets thrown out of the unit at high speed.



- Before carrying out any work of fault rectification, interrupt the supply of electricity to the machine, by putting off the main switch and pulling out the power supply connector!
- Do not insert any foreign metallic body (e.g. tool) into the changing head under any circumstances whatsoever! Clean the changing head in the installed condition only with a non-metallic tool!
- Dirt and contamination or jammed electrode caps must be removed only with the help of aids (tweezers). Never insert your finger in the openings of the tools under any circumstances!
- Wear tight-fitting clothing, protective clothing (gloves, safety boots, face protection)!

ATTENTION**Damage to machine caused by water of the welding gun cooling system**

There is the risk of damage to the machine if the water flow of the welding gun cooling system is not interrupted before the electrode cap is extracted. Water may enter the machine. In addition, there is the risk of slipping near the machine by the water discharged.

- Interrupt the flow of water in the welding gun cooling system during electrode cap change!
- Use water extraction!

4.6.2 Electrode cap change

Initializing the machine

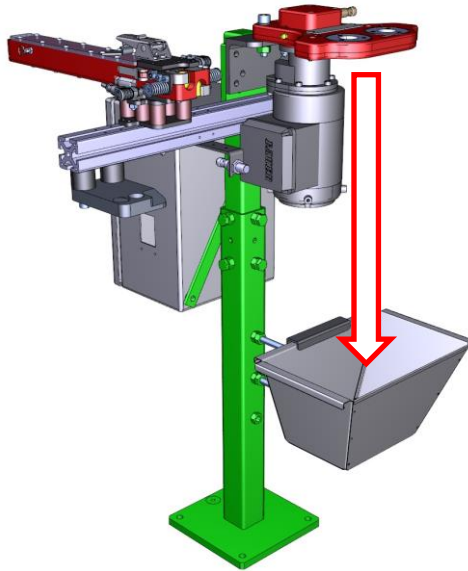

- Electrode cap changing head(s) – Pulse »B1«.
- Any electrode cap still held is released and falls into the electrode cap collecting box. In the »V2« setup type, the cap is extracted through the electrode cap extraction unit.

Pulling out the electrode cap

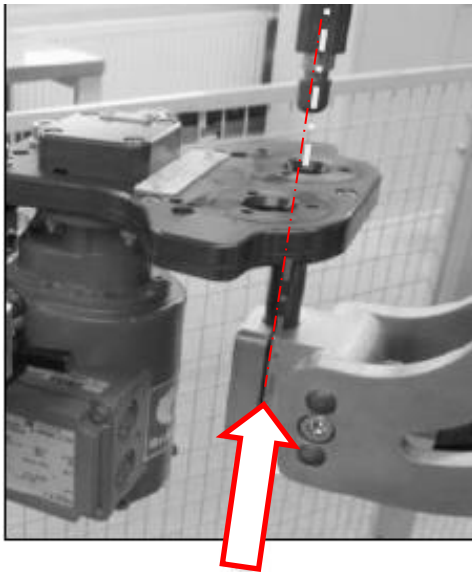

- The welding gun, with the lower electrode holder, is immersed from below in the right open changing head.

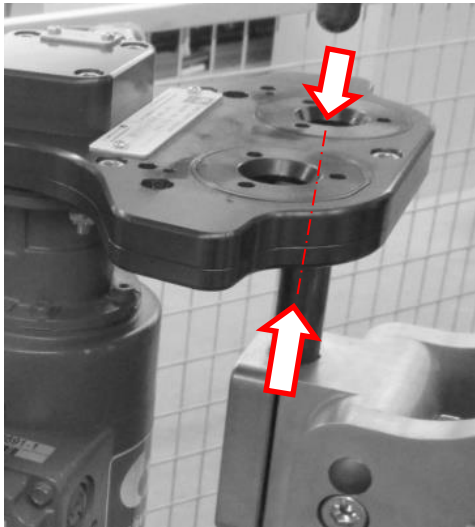

- The cap axis (at the welding gun) must be positioned coaxially with respect to the axis of rotation of the changing head.

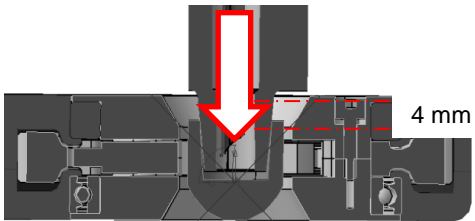

- The immersion depth of the welding gun with the electrode cap in the changing head must be approx. 4 mm (measured from the top edge of the changing head and lower edge of the electrode cap).

Starting the machine

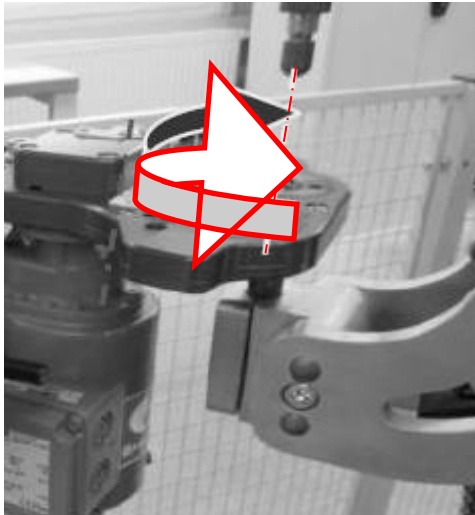

- The electrode cap is clamped in three jaws and turned clockwise on the holder cone.
- The proximity switch »B1« monitors the angle of rotation and makes signals available for evaluation.

The signal can be used as a signal for the feeding system to drive out the movable welding gun from the changing head.

Move the welding gun out of the machine

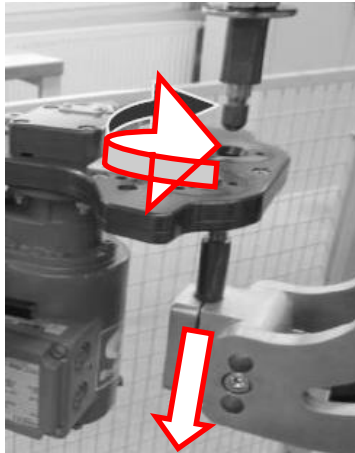

- While the electrode changing head is rotating, the welding gun is moved back in the direction of the axis of the electrode cap changing system out of the machine.

The electrode cap is extracted and remains in the changing head.

NOTICE



Electrode cap change

The electrode cap is already clamped in the jaws of the changing head after $\frac{1}{4}$ revolution and turns on the cone of the holder. The welding gun should be moved out of the machine as quickly as possible.

Stopping the machine

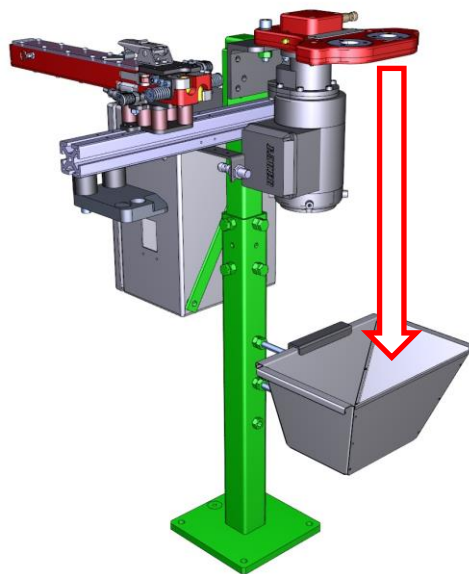

- In the »H« setup type, the electrode cap changing system is started in opposite direction of rotation.

The electrode cap is released and falls into the collecting box.

- In the »V2« setup type, the cap is extracted through the extraction unit and collected in the collecting box.

Checking » Electrode cap extracted« (sensor »B4«)

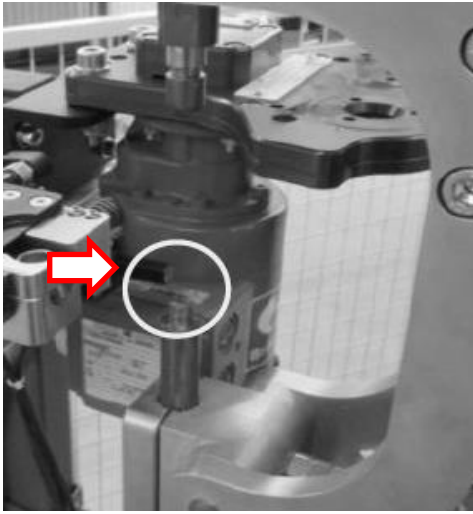

- The welding gun with the cap cone must be positioned at a specific distance in front of the sensor »B4«.
- Signal evaluation:
 - Electrode cap extracted
 - electrode cap not extracted (operation must be repeated)

Inserting the lower electrode cap

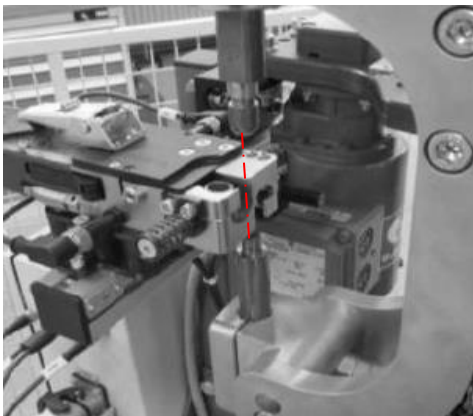

- The welding gun with the lower electrode holder is positioned coaxially with respect to the electrode cap in the removal position of the electrode cap cartridge.
- The electrode holder moves the axial direction of the cone slightly into the electrode cap.
- Press electrode cap lightly against rubber cushion packet (ca. 2-3 mm).

ATTENTION



Damage to the machine without welding gun compensation

There is the risk of damage to the machine if the welding gun do not have their own tongs compensation.

- Accordingly, integrate the welding gun with its own compensation in the system.

Removing the electrode cap

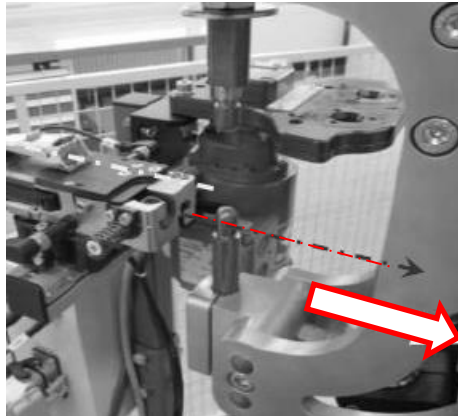

- Move out the welding gun with new electrode caps from the removal position of the electrode cap cartridge in parallel to the cartridge's axis.

Only this way is it ensured that a new electrode cap slides into the removal position in the electrode cap cartridge.

Checking »Electrode cap inserted (sensor »B4«)



- The welding gun with the new cap inserted must be positioned at a specific distance in front of the sensor B4.
- Signal evaluation:
 - Electrode cap inserted
 - Electrode cap not inserted (operation has to be repeated)

Changing the upper electrode cap

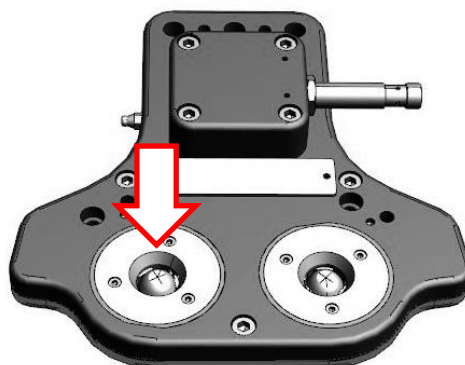

- Repeat the procedure as described above for the upper electrode cap. Exception: Use changing head (left)

Secure electrode caps

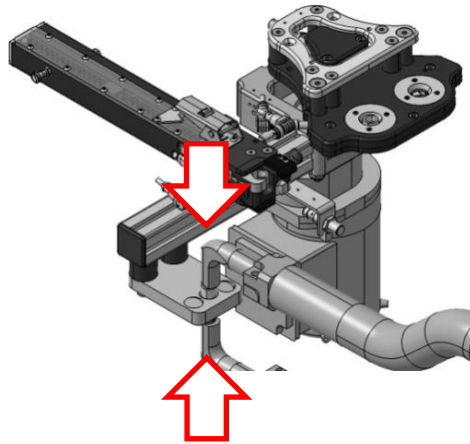

- To be sure, close the welding gun with the inserted electrode caps with a specified pressure once or more on the electrode cap pressing plate (welding gun electrically de-energized with welding force).

4.6.3 Programming the electrode cap pressing plate

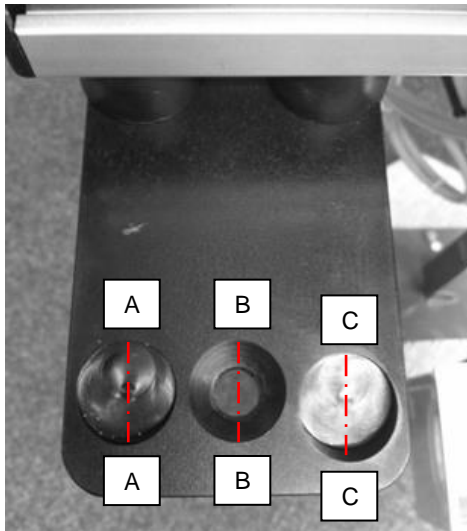

A-A

- E-shaft position 90° / 15°

B-B

- E-shaft position 90° / 90°-15° / 15°

C-C

- E-shaft position 90° / 25°-30°

A-A – E-shaft position 90° / 15°

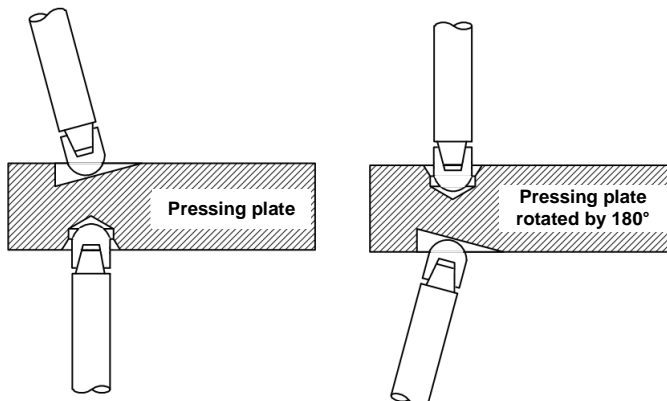

- If the 15°-shaft is located on the bottom side of the electrode cap pressing plate, it has to be rotated by 180°.

B-B – E-shaft position 90° / 90°-15° / 15°

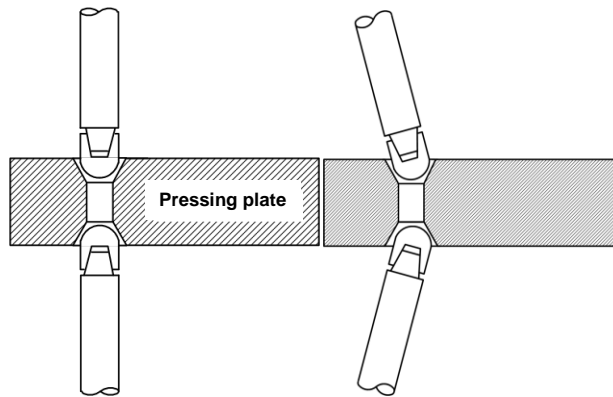

- E-shaft position 90° / 90°-15° / 15°

C-C – E-shaft position 90° / 25°-30°

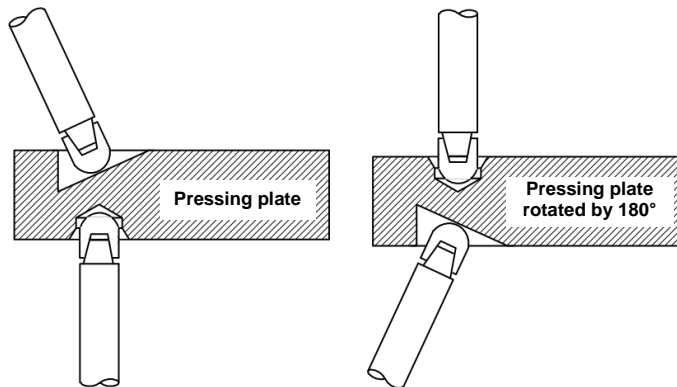

- If the 30°-shaft is located on the bottom side of the electrode cap pressing plate, it has to be rotated by 180°.

5

Transport Installation Connection

5 Transport, Installation and Connection

In this Chapter you will learn about how you can transport and install the machine. General information on installation, connection of operating materials as well as on testing procedures before starting the machine for the first time provide you with an overview of the work to be performed in this connection.

5.1 General safety instructions »Transport, Installation and Connection«

NOTICE



Observe the safety instructions





In addition to the special safety instructions presented in this Chapter, the safety instructions in the chapter »Safety instructions« as well as all warnings and warning icons on the machine must be observed and followed!

DANGER



Risk of injury during transport, assembly and installation work

Basically, there are risks posed in case of human misconduct and insufficient personal protection. Serious injuries right up to fatal injuries are possible.



- Never step under lifted loads!
- Wear personal protective clothing!
- Work areas or hazardous spots must be cordoned off with a red and white barring chain or with a site fence!
- Make sure that the personnel appointed for carrying out transport, installation and connection work is conversant with this work and has been trained!
- The specialists deployed must be able to understand the national language of the company operating the machine!
- Accident prevention and safety regulations (operator, machine manufacturer) must be observed!



5.2 Transportation procedure

The machine is secured on a pallet as a complete unit ready for operation and delivered in packed condition. The machine must be prepared for transport in order to be able to carry out the actions pending in this connection safely such as, for example, lifting the machine.

5.2.1 Transport with a forklift

For inhouse transport of the machine it is recommended to use a forklift (or another suitable floor conveyor) with adequate load-bearing capacity.

DANGER







Danger posed by suspended loads dropping/falling down while moving the transport units within the company's premises

Dangers are present due to human misconduct and insufficient or incorrectly secured loads. Suspended loads could fall down and lead to serious injuries right up to death.

- When moving the transport units within the company's premises, use a forklift (or other type of floor conveyor) with sufficient load capacity and adequate fork length! Secure the transport unit against unintended shifting of its position! Put anti-slip rubber mats on the forks of the floor conveyor for this purpose!
- When moving the transport unit within the company's premises using an indoor crane, pay attention to adequate load capacity of the crane! Load straps must be used to lift out the transport unit with a crane!
- Observe the center of gravity of the transport unit!
- Never step under lifted loads!
- The transport and installation of the transport units must be performed by trained specialists only!
- Wear personal protective equipment!

WARNING

Danger of injury due to unsecured transport routes

There is a danger of tripping and slipping when transporting the machine.

- The transport routes in the factory hall must generally be kept free and designed to be well illuminated and without obstacles!
- Ensure safe footing by using rough-textured floors!

ATTENTION



Possibility of occurrence of transit damage

The machine is sometimes composed of components, which may get damaged in case of improper handling during transport.

- Avoid impacts, jerky lifting or setting down of the machine!
- Do not use components of the machine as slinging points for picking up the load!
- Avoid crushing lines, cables or hoses during transport as well as when setting down the machine!
- To prevent damage to the machine during transport by abrasion of cables and lifting straps at components of the machine, intermediate layers made from soft material, protective corners or scantlings must be used!

5.3 Unpacking the machine

The machine has been secured prior to transport on a transport unit (pallet) with strapping tape against tilting over and then covered with packaging and protective material. Before installing the machine the packaging material has to be removed and disposed of in accordance with the environmental conservation regulations applicable.

1. Unpack the machine carefully. Dispose of the packing material in compliance with the applicable local statutory provisions!
2. Remove transport locks (strapping tape for securing the machine on the pallet) if used.
3. Carry out visual inspection for damage.

ATTENTION



Damage to property at components of the machine

By using cutter blades or sharp objects for tearing off protective films and cardboard used while unpacking the machine, cables or connecting lines on the machine, which are located below the packaging material, may get damaged.

- Unpack the machine with utmost caution!
- Remove adhesive tapes, protective and blister films as well as cardboard by hand, if possible, and if necessary, use scissors (no cutter blades!)

WARNING



Risk of injury and damage to property by the machine tipping over without securing the machine while unpacking

There are risks posed by ignoring the safety instructions and handling actions for unpacking the machine.



- Observe and follow the safety instructions specified and instructions for action prescribed for securing the machine while unpacking!
- Before tearing off the strapping tape, secure the machine with load slings (e.g. holding via a load trolley) or by holding the machine tight by a second person against it tipping over!
- Wear personal protective equipment!

The machine must be unpacked as described in the following. The pictures are meant to present a schematic diagram and may vary depending on the scope of supply or depending on the machine design. In most cases, multiple machines are fixed on one pallet and packed.

Transport, Installation and Connection



- Choose a suitable place to unpack the machine!
- Pay attention to the access options for a forklift or other lifting equipment!
- Remove the delivery note or accompanying documents of the machine from the film pocket on the outer packaging!
- Remove the stretch film and the outer cardboard boxes!



- Remove the stretch film and the film cover sheet below the cardboard boxes!



- Loosen the adhesive tape that holds the folded corners of the bubble wrapping film with the cardboard wrapped around the machine!
- Pull off the adhesive tapes by hand!
- Remove the bubble wrapping from the machine by hand!



- Remove the remaining cardboard that is below the bubble wrapping!



- Cut through the adhesive tapes of the foam cushion bags with a pair of scissors!
- Take off the foam cushion bags carefully from the machine components and remove them!
- Secure the machine with the help of appropriate means against wobbling, tipping over or falling over! For securing the machine (against falling down) use a lifting strap or some other load sling with adequate load capacity.



- Remove the locking screws between the basic leg stand and the pallet!
- Lift the machine from the pallet!
- Position the machine at the place of deployment!
- Dispose of the packaging material in accordance with the local regulations! Dispose of cardboard boxes and protective packaging made of plastic separately and professionally!
- If the machine needs to be shipped once again, it is recommended to secure and pack the machine as described above in the reverse order!



IMPORTANT



Environmental conservation

The packaging material, which is meant to protect the machine during transport against environmental influences, is capable of being recycled 100%.

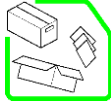

- Make sure that the packaging material removed, especially the films, are not disposed off uncontrollably in the environment!
- Collect cardboard boxes and films after removing the outer packaging of the machine separately!
- They must be disposed of professionally in compliance with the regional provisions and environmental protection regulations!

5.4 Erecting and assembling the machine



The erection area must be free from objects, before the machine can be erected at the final place of installation taking the necessary space required into consideration.

WARNING

Risk of crushing and shearing posed by moving loads while setting up the machine

There are risks if personnel remain between moving loads and fixed elements while the machine is being set up and positioned. There is the risk of suffering crushing or shearing injuries at sharp-edged machine parts.

- Make sure (visual check) that no one is present in the danger zone at the place of installation.
- Wear personal protective equipment!
- Observe the work instructions of the operator!
- Observe the accident prevention regulations!







ATTENTION

Keep the working area/installation location free

Any objects put down or stored at the installation site obstruct the transport and assembly works.

- Nothing should be stored or put down directly at the installation site of the machine during transport, assembly and installation work!
- Escape routes must be freely accessible and visible at all times!







WARNING

Risk of falling down by cables and supply lines

There is a risk of injury if personnel trip and fall down over cables, supply lines that have not been laid properly.

- The installation area must be cordoned off during the installation and connection work (e.g. red and white chain)!
- Make sure that entry to the installation site is prohibited for unauthorized persons!
- Wear personal protective clothing!
- Attention must be drawn to connecting cable laid on the floor, if necessary, by an information sign!
- Cables and supply lines must be laid in cable ducts if possible or underground, and if necessary, black-yellow marked cable stepping protection boards or driving over protection boards must be used!

5.4.1 Operating and ambient conditions

The following operating and ambient conditions must be met and observed for the safe and proper use as intended.





Property	Physical condition
Ambient temperature (Hall)	0°C - + 40°C
Atmospheric humidity	Dry installation site with low atmospheric humidity (30 % - 60 %) – no moisture
Altitude	Max. 2,500 m above sea level
Contamination	No high pollution caused by dust, acids,
Ex protection	Deployment in explosive atmosphere is prohibited – the machine does not have ex protection
Electromagnetic compatibility	No restrictions! Impairment caused by welding transformer is barely possible.
Miscellaneous	Sufficient lighting, required 250 Lx according to workplace regulation - ArbStättV §7)

5.4.2 Work, service and protected areas

Areas of the machine that require particular caution are marked by warnings and safety icons at the relevant locations. They must be clearly visible for the personnel working in such areas.

The working, service, and protected areas of the machine constitute the danger zone.

WARNING

Risks posed by ignoring the danger zone and the safety clearance to the machine

There are risks posed by ignoring the danger zone and the safety clearance to the machine by electrical, mechanical and thermal energy sources, as well as special residual risks.

- Observe the danger zones and hazard warnings at the machine machine !
- The required safety clearance of 800 mm around the machine components must be observed! The safety clearance must be ensured!
- No objects may be put down or stored within the working and service areas!
- Do not climb on the machine!
- The company operating the machine must ensure that unauthorized persons (such as visitors) do not have entry or access to the danger zones (working area, service area or protected areas) of the machine!
- Work areas and duties of the personnel: ► Chapter 6.2!

5.4.3 Space requirements

NOTICE



Observe the dimensions on the dimensional drawing

The exact dimensions of the machine are provided in the relevant order-specific dimensions sheet.

5.4.4 Setting up the machine

The hall floor at the erection location of the machine must be level and solid. The load capacity of the hall floor must be equivalent to the weight of the machine (approx. 45 kg) (► also see Chapter 4.1).

- Lift the machine with the help of a crane or another lifting equipment – alternatively, use two persons – to lift it from the pallet. Never put the machine down from the pallet alone.
- Put the machine down immediately after lifting it on the floor of the hall at the place of erection.
- Position the machine within reachable distance to the movable welding gun.

The reachability or the action radius of the welding gun feed must be taken into consideration in doing so.

In addition, a working and service area of approx. 800 mm around the machine must be maintained in order to ensure that maintenance and servicing work can be done.



- After positioning the machine align it horizontally.
- Anchor the machine with the help of all 4 bore holes of the basic leg stand (refer to the drawing alongside) by an appropriately dynamically loadable dowel connection with the machine hall floor.

Means of fastening are not included in the scope of supply of the machine.

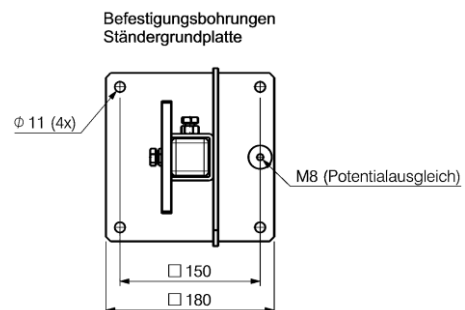

WARNING



Risk of injury and risk of damage to the machine posed by the machine falling over

There are risks if the machine is not connected properly (incorrect means of fastening, unevenness in the machine hall floor) with the machine hall floor. The machine could tip over and fall down.



- Use suitable means of fastening in order to connect the machine securely and tightly with the machine hall floor! Means of fastening are not included in the scope of supply of the machine.
- Do not use the means of fastening from the packaging process under any circumstances whatsoever!

- Align the machine once again before tightening the connection.
- Integrate the machine via the bore hole of the basic plate of the basic leg stand into the potential equalization of the overall system!

When using foundation frames, the potential equalization must be implemented via the screw connection.



5.4.5 Setting up the machine (Height adjustment of the basic leg stand)

The machine has been packed so that it is optimized for transport and it must be aligned after being erected at the desired working height. In order to achieve exact positioning of the changer tools, the required height can be adjusted with the help of the height adjustment mechanism on the basic leg stand of the machine and fixed with the help of pinned fitting.

NOTICE



Pinned fitting

Pins to fix the height adjustment are not included in the scope of supply of the machine. Suitable fastening material must be ensured by the company operating the machine!

WARNING



Risk of suffering crushing injuries with missing or improper pinned fitting

There are risks if the machine is not fitted with pins properly (incorrect means of fastening) or not fitted with pins at all. The combi unit could slip on the basic leg stand and cause crushing injuries or collisions, which may also lead to damage to the machine.



- Use suitable means of fastening in order to fasten the machine securely and tightly with pins! Do not use the means of fastening from the packaging process under any circumstances whatsoever!
- Do not put the machine into operation without fastening it with pins under any circumstances whatsoever!
- You must check and ensure proper fit of the combi unit on the basic leg stand before putting it into operation!

Transport, Installation and Connection



- Align the machine with the help of the adjustable height basic leg stand at the desired height!

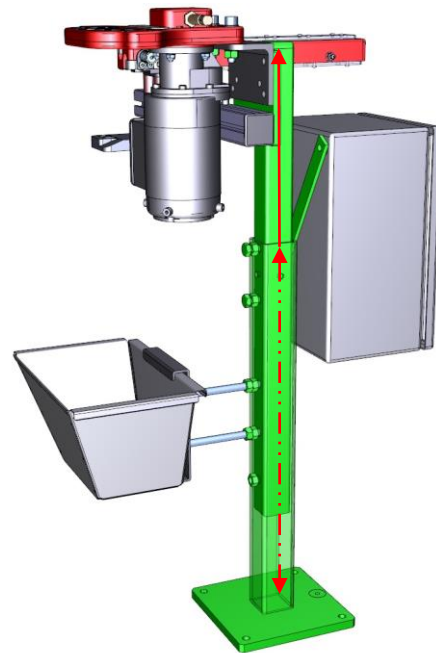

- Tighten 4 x hex screws »M10 x 16« with a SW-17 size wrench.

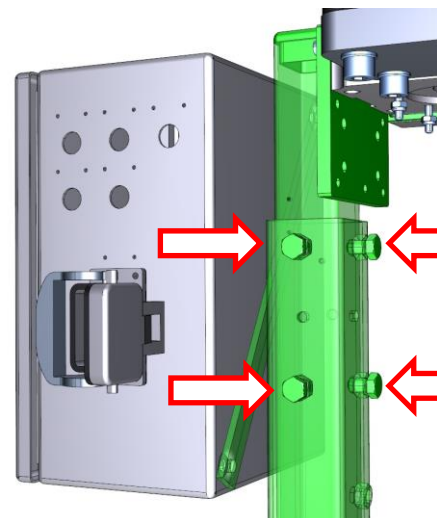

- Fix the height alignment of the machine for permanent locking with 3 cylindrical pins of type »ISO 8735 dia. 8« or with a continuous cylindrical pin.
- Alternatively, the bottom part of the basic leg stand can be permanently welded to the top part of the basic leg stand.

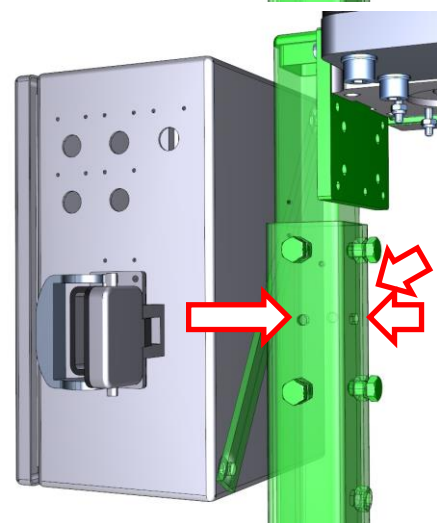

5.5 Connecting the machine (Energy supplies)

After the machine has been erected and installed, the electrical, control and pneumatic equipment is connected by specialists.

WARNING

 **Risk of injury and damage to property in case of unexpected automatic start-up of the machine or execution of movements after connecting the equipment**

While equipment is being connected, there is a risk that the machine components could start up unexpectedly or execute movements. This may cause severe injuries to the fingers when reaching into the tool.









- Have connecting works carried out only by qualified personnel!
- During installation, disconnect the machine from the electrical energy supply as well as from the compressed air supply and secure it from being switched on inadvertently!
- Observe the safety clearance and wear protective equipment!
- Ensure that no unauthorized persons have access to the machine during installation!
- Never reach into the tools!

WARNING

 **Risk of stumbling and falling down posed by cables and lines lying on the floor**

There is the risk of injury posed by stumbling and falling down over cables and lines lying on the floor.





- Cables and lines must be laid near the machine so that they are strain-relieved!
- Pay attention to all cables and lines lying on the floor!
- Avoid the formation of loops or knots in the cables and lines lying on the floor!
- Ensure that no unauthorized persons have access to the machine during installation!

NOTICE

 **Connection and circuit diagrams (Electrical components, Pneumatic unit)**





Refer to the connection diagrams for detailed information on the connection of operating materials! These are an integral part of the Installation Manual.

5.5.1 Pneumatic connection

After the machine has been set up, you can connect (► Chapter 4.1.2) the pneumatic equipment. The pneumatic system components of the machine are already pre-installed and cabled on the part of the manufacturer. The connection to the solenoid valve (interface) is made without any maintenance unit connected in between and directly on the compressed air supply provided by the operator.

For correct and safe connection of pneumatic components to the supply, accordingly, preparatory work needs to be done.

WARNING



Risk of injury due to compressed air

In the course of establishing pneumatic connections, when the hose connection becomes loose due to a faulty connection or connector, or the input pressure gets too high, there is a risk of compressed air leaking from the loose connection or equipment under high pressure. The end of the hose moves uncontrollably and may cause severe eye injuries.

- Work on the pneumatic systems should be performed only by qualified personnel with special knowledge and experience in pneumatic systems!
- Before working on pressurized systems and assemblies, switch off the compressed air supply at the main valve of the supply and secure the condition! The pressure drop is to be monitored on the manometer!
- Never open the system when it is pressurized! Consider potential remaining energy in the pneumatic actuators!
- Personal protective equipment is to be worn when working at pressurized systems!
- Check pneumatic hose lines in appropriate intervals for bends and cracks and replace where necessary!

5.5.1.1 Connect the machine

Preparation (to be carried out before the connection work)

1. The system is to be disconnected from the assembly hall supply at the shutoff valve of the service unit and at the main shutoff valve.
2. The disconnected state must be secured at the main shutoff valve with a padlock or any other appropriate safeguard.
3. Actuators or other machine components, which may fall due to a drop in compressed air, must be intercepted in a suitable way or safeguarded against!
4. The pressure drop is to be monitored visually at the pressure gage!
5. The personal protective equipment, in particular safety goggles (or face protection) and protective gloves, must be worn!
6. Connect the machine to the compressed air supply provided by the operator taking the required operating pressure of 4-6 bars into consideration!

The solenoid valve(s) and the pneumatic components of the machine are already pre-installed by the manufacturer.

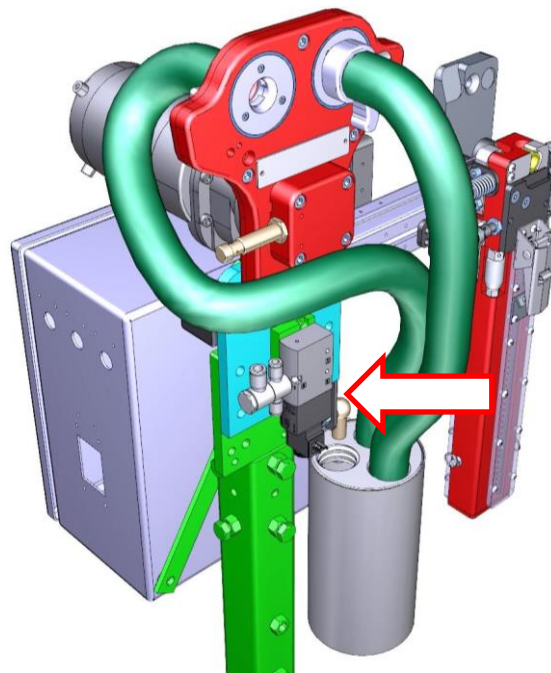



Compressed air connection – Solenoid valve (here: Setup type »V« – without piping)

CAUTION

 **Risk of injury by electrode caps that are thrown out (electrode cap extraction unit for setup type »V2«)**

There is the risk of injury (eyes) if the hose of the electrode cap extraction unit is not installed or if it is not installed properly on the extraction nozzle at the changing head, which means that electrode caps could get thrown out by the extraction operation.

- Before starting any connection work, interrupt the supply of compressed air, as well as the electricity supply to the machine by putting off the main switch and pulling out the power supply connector!
- Inspect the connection and extraction hose for tight fit and for damage!
- Wear protective clothing (gloves, shoes, safety goggles, face masks)!



Preparation (to be carried out after the connection work)

1. When the works have been performed, the main shutoff valve can be reopened only after the pneumatic system has been closed professionally!
2. Reconnect the unit to the assembly hall supply.
3. Remove the padlock from the main shutoff valve and switch the main shutoff valve back on!
4. The pressure rise is to be monitored visually at the pressure gage! In the event of anomalies, the main shutoff valve must be closed again immediately. Following this, the cause of the fault must be found and removed.
5. Provisional fuses of actuators and components must be removed again after pressure has built up!

5.5.2 Electric connection

After the machine has been set up, you can connect (► Chapter 4.1.2) the electrical equipment. The electrical elements of the machine are already pre-installed and cabled on the part of the manufacturer. The connection adapter on the electrical switch box forms the interface at the customer's end for the 400 V AC supply.

DANGER

Danger to life caused by electric shock when coming into contact with live electrical equipment

Touching live conductors or components that carry the intended voltage, or in case of contact with live conductors or components that carry voltage in faulty condition (in particular due to insulation faults), as well as due to electrostatic processes such as touching statically charged components, may result in danger to life due to electrical shock!

There is a risk of fire, electric shock, burns and death if people approach live components, especially in the high voltage area.

After switching off the machine, remaining electric energy still resides in the lines, devices and components for approx. 5 minutes.

The electrical switch box and terminal boxes contain live components. Opening the door of the electrical switch box or removing the cover of the terminal box may cause death, serious injuries or damage to property caused by electric shock. The main feed terminals are energized, even if the main switch is turned off.

Non-compliance (such as freely accessible contacts, incorrect installation of the earth line, etc.) can result in electric shock and ultimately in the most severe injuries (cardiac arrhythmia, severe burns, blindness) and death!

- Observe a safety clearance around energized cables and avoid contact with them under any circumstances!
- Have work at the electric supply or at freely accessible energized devices performed only by qualified electricians and with the power switched off! Disconnect the machine from the main power supply and secure against unintentional restart, if running parts of the machine can be accessed using tools.
- Keep the electrical switch box locked at all times! Access only by authorized personnel!
- Terminal boxes must always remain closed during operation. Terminal boxes may only be opened if the machine is switched off and de-energized!
- Check the electrical equipment of the machine at regular intervals (inspection every 4 years in accordance with DGUV V3)! Replace singed or scorched cables! Inspect insulation of all moving cables for damage at regular intervals during repair and maintenance works! Eliminate loose connections!
- Regular safety briefings with the operating personnel about the risk of the remaining power.



For correct and safe electrical connection to the power supply, appropriate preparatory work needs to be done.

Preparing the machine before starting work on electrical equipment:

1. Deactivate (electric, pneumatic, media)
2. Secure against switching on
3. Determine electrical de-energization (if necessary, disconnect physically: pull out the connector)
4. Earth and short-circuit
5. Cover or block off adjacent energized parts/assemblies
6. Interrupt the protective circuits (machine, adjacent machinery)

5.5.2.1 Connect the machine

1. The machine is ready for connection specifically for each order, to be connected to the electrical power supply and thus, delivered so that it is ready for operation.
2. Lay the connection line to the machine with strain relief so that no danger zones are formed.
3. Connect the machine accordingly to the operator's electric power supply network taking the required voltage limits into consideration!
4. To do this, insert the connector of the connection line (to the power supply of the machine) into an appropriately assigned power socket.

5.5.3 Connection of the control/EMERGENCY STOP circuit

The machine is already pre-installed (electrical components, sensor system) on the part of the manufacturer and cabled. The machine has pre-installed sensor systems on the part of the manufacturer with appropriate signal provision. The onus for evaluation/utilization of the signals lies with the manufacturer of the overall system.

The manufacturer of the overall system in which the machine is integrated, must integrate this in the higher-level control and EMERGENCY STOP circuit. The machine has no EMERGENCY STOP function of its own.

The manufacturer of the overall system installs suitable safety and protective devices for the case that the machine / the overall system can be shut down immediately in case of an emergency.

NOTICE



Instructions for the distributor (Integrator) of the overall system

The instructions for the integrator of the overall system in ► Chapter 1.1.1 must be observed and followed!

6

Start-up Settings

6 Start-up and Settings

In this Chapter you will learn about how you can prepare the machine for operation.

The basic requirement for safe and fault-free operation of the machine is the knowledge of the safety instructions. The Installation Manual, especially the safety instructions must be read and observed by all those who work on and with the machine.

6.1 General safety instructions »Start-up and Settings«

NOTICE







Observe the safety instructions

In addition to the special safety instructions presented in this Chapter, the safety instructions in the Chapter »3 Safety« as well as all warnings and warning icons on the machine must be observed and followed!

The machine must be handled and operated only according to its proper or intended use. The operation of the machine is permissible only with completely installed and functional safety and protective equipment. Putting the machine into operation is prohibited until it has been established that it meets all requirements of the Machinery Directive – especially the requirements with respect to safe operation of the machine and working on the machine.

WARNING

Risks posed by moving machine components

There is the risk of injury when reaching between components during the operation of the machine and by ignoring the danger zone, the safety clearance to the machine components as well as when removing protective casings for safeguarding against the mechanical energy of moving machine components.

- Before putting the machine into operation, the operating personnel must satisfy themselves by visual inspection that nobody is inadvertently present in the danger zone or is reaching into it! The machine should be started only if this is ensured! No unsupervised operation!
- Never reach into moving machine components!
- In case of an emergency, the main switch (optional fitting) must be put to the switch position »0/OFF«!
- Do not remove, open or operate the machine without protective devices under any circumstances!
- Observe the danger zones and hazard warnings at the machine !
- The personnel must check the machine for externally identifiable damage and the functionality of the safety equipment once per shift!
- The operator must regulate the working areas, responsibilities and personnel in a binding operating instruction!

6.2 Workstations and tasks of the personnel

There are no other workplaces on the machine for operation as well as for carrying out maintenance, cleaning or servicing work. The machine is designed for automatic operation within a welding cell enclosed by a protective fence. Interventions during operation by the operating personnel are not necessary.

Refilling the quick-change cap cartridge with electrode caps, reconfiguring the machine, as well as working for fault rectification can be done by one person without any external aid or assistance. Nevertheless, should it be necessary to involve another person for providing support when carrying out certain repair or reconfiguration work, the machine must be switched off for this purpose and switching it on again must be prevented reliably with the help of suitable measures, e.g. locking the main switch.

WARNING



Risks posed by the presence of more than one operator

There are risks posed by more than one operator remaining present during the operation of the machine!



- Before putting the machine into operation, the operating personnel must satisfy themselves by visual inspection that nobody is inadvertently present in the danger zone or is reaching into it! The machine should be put into operation only if this is ensured!
- The operator must regulate the working areas, responsibilities and personnel in a binding operating instruction!
- It is prohibited for third parties to be present or to gain entry to the machine!

WARNING



Hazards due to failure to observe the behavior instructions and authorizations

There are risks posed by unauthorized actions at the machine.



- Observe all instructions given!
- Do not perform any activities for which you have not received authorization! Consult qualified personnel in case of any doubts!
- Any operating method endangering safety must be prohibited!

6.3 Control elements

The machine has the following controls:

- Main switch (electrical power supply switch) – optional fitting

6.3.1 Main switch (optional)

The machine is fitted with a line disconnecter. The motor circuit breaker is coupled with the line disconnecter, which, when tripped, also switches (off) the line disconnecter to the position »0« (Off).



Switch position	condition
Position »0/OFF«	machine is switched off (supply of electricity is interrupted)
Position »I/ON«	machine is ready for operation (power supply to the machine is switched on)

6.4 Start-up tools

Before putting the tools of the machine into operation, all fastenings and connections must be checked once again for tight fit. The welding gun must be programmed in accordance with the electrode cap changing system.

WARNING



Risk of injury posed by defective or missing safety and protective devices

There are risks after switching on the machine, if there are damages or defects or safety and protective devices are missing.



- In case of localized and identified damage, do not put the machine into operation under any circumstances whatsoever! Replace defective components or rectify the faults identified before switching on the machine!
- Check the electrical and mechanical components of the machine after installation and connection and before putting the machine into operation for fault-free and undamaged condition!
- All protective and safety equipment as well as parts of the paneling must be installed completely and permanently!
- Carry out all preparatory measures before putting the machine into operation for the first time (► Chapter 6.4.2)!

WARNING



Risks posed by reaching into freely movable machine components during operation

There are risks of injury when removing the protective casings by mechanical energy in moving machine components.



- Do not operate the machine with defective, disabled or removed safety and protective devices.
- Never reach between moving machine components!

WARNING



Risk of injury during fault rectification (jammed workpieces) at moving components

You may suffer injuries while removing jammed workpieces that may lead directly or indirectly to severe physical injury or damage to property if the tension between the jammed workpiece and the machine components gets released suddenly.



- Before taking up the work of fault rectification, disconnect the machine from the power supply!
- Never remove jammed workpieces or foreign objects with your bare hand! Suitable aids must be used for removal (e.g. welding gun)!
- Fault rectification work on the machine with safety and protective devices dismantled should be carried out only by specialists who have been specially trained and are very familiar with the machine!

6.4.1 Programming the »Electrode cap changing system«

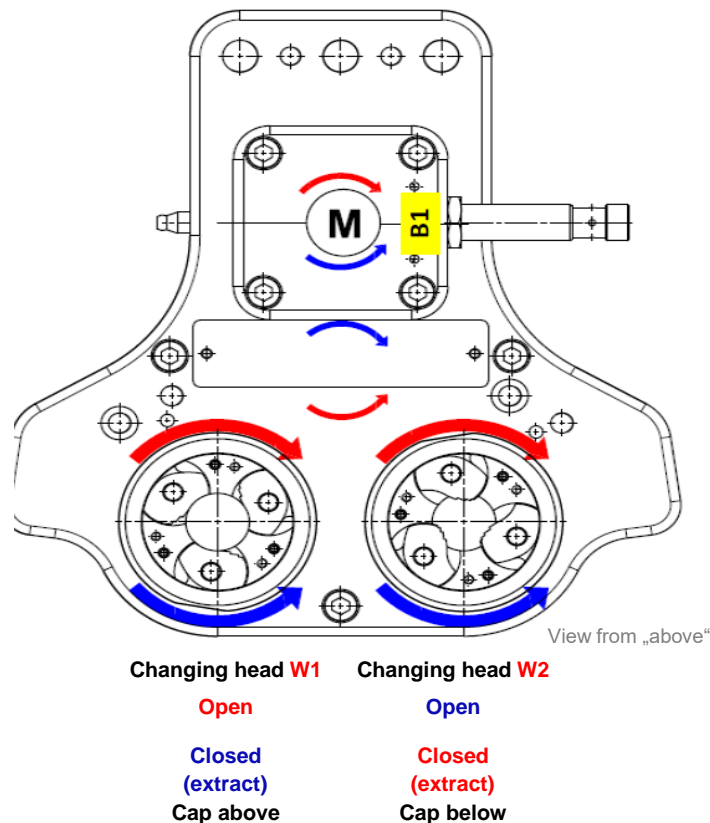

During programming, you must pay attention to see that with electrode shafts/holders fixed with screws, the respective electrode cap is released with the changing head whose direction of rotation matches the tightening direction of the electrode shaft/holder. The electrode cap must be placed centrally above the changing head.

For programming or control-related integration of the tools, use the schematic representation given in the following.



BWS 5710 – Gear unit with arrows for direction of rotation (designed for right-handed electrode shaft thread)

WARNING

Risk of injury posed by electrode caps being thrown out

During the work of programming and commissioning, electrode caps may get thrown out of the electrode cap changing system. Severe injuries may occur to the eyes.

- During the programming and commissioning work on the electrode cap changing system, wear safety goggles!
- Carry out programming and commissioning work on machines of the »V2« setup type only with the electrode cap extraction unit completely installed and running!

WARNING



Risk of injury posed by unexpected start-up of the electrode cap changing system

There are risks during programming and commissioning work if the electrode cap changing unit starts up unexpectedly.



- Secure the machine against being switched on inadvertently during programming and commissioning work! Disconnect the energy supplies!
- Make sure that no unauthorized persons have access to the machine during the programming and commissioning work! Prohibit third persons from entering the working and service area!

6.4.2 Visual inspections before putting into operation

Before putting the machine into operation, you must carry out the checks described in the following to ensure safe and proper use as intended.

No.	Description
1	Inspect the machine for contamination and damage <ul style="list-style-type: none">• Before putting the machine into operation for the first time or after a longer period of standstill, the outer housings of the machine components must be checked for dirt or contamination (dust deposits) and damage!
2	Inspecting safety covers <ul style="list-style-type: none">• All fixed safety covers must be checked for their presence, tight fit and damage.• In case of damaged safety covers (e.g. cover of the gear unit of the drive unit) there is the risk of suffering injuries. Before putting the machine into operation, the damage identified has to be rectified.• You must check bolts and connections. Retighten them as required.
3	Checking the switch position of the main switch (optional fitting) of the machine <ul style="list-style-type: none">• You must check the position of the main switch of the machine: Switch position »0/OFF« or »I/ON«.
4	Check the integrity of the connecting cable/pneumatic hoses of the machine <ul style="list-style-type: none">• Check the connecting cable of the machine for damage (e.g. kinks of the cable, damage to the insulation, singed or disconnected metallic inclusions in cables of the power supply caused by flying sparks during welding).• When identifying damage to the cable of the power supply, the machine should not be connected to the power supply network of the energy supply.• If necessary, disconnect the machine from the power supply and replace the defective cable promptly.

6.5 Filling the electrode cap cartridge (Initial filling)

The machine is delivered with unfilled electrode cap cartridge. The frequency of this filling or the replacement of the cartridge is cycle-dependent. In case of a full changing cartridge, there are 10 electrode caps in the cartridge shaft.

The fill levels of the cartridge shafts are monitored with the proximity switches »B2« and »B3«. The corresponding signals for requesting filling or replacing the quick-change cap cartridge are made available to a supervisory controller.

ATTENTION



Damage to the machine when »running the quick-change cap cartridge empty«

There is the risk that the cone of the electrode holder as well as the cartridge head may get damaged while trying to pull out a new electrode cap and there are no more electrode caps in the cartridge removal unit.

Complete emptying of the quick-change cap cartridge should be avoided. If the last electrode cap gets removed, no new electrode cap can be pushed into the cartridge removal unit and cumbersome initial filling becomes necessary.

- Change the quick-change cap cartridge with a signal output »cartridge empty« after another electrode cap change or fill it up!
- Make sure that there are always adequate number of electrode caps in the quick-change cap cartridge. Change the quick-change cap cartridge in time or fill it up.

Proceed as follows for the initial filling:

1. Satisfy yourself that the machine is switched off and secured.
2. Open the tension lock with the safety clip of the electrode cap cartridge.
3. Pull out the quick-change cap cartridge from the cartridge head.
4. Fill up the cartridge head with electrode caps. In doing so, pay attention to see that the electrode caps must be pressed in front so far until the first electrode cap is visible in the cartridge removal unit (removal position).

WARNING



Risk of injury posed by falling quick-change cap cartridge

There is the risk that, especially while releasing the tension lock of the design setup type »V2«, the quick-change cap cartridge falls.



- Hold the quick-change cap cartridge tight when releasing the tension lock!
- Safety boots must be worn!

WARNING



Risk of suffering crushing injuries while positioning an electrode cap manually in the cartridge removal unit

There is the risk of injury when positioning the electrode cap manually in the cartridge removal unit. Due to the spring force (compressing spring separation) in the cartridge head, fingers could get crushed.



In addition, there is the risk of suffering crushing injuries if your finger gets caught while inserting the quick-change cap cartridge between the cartridge and the cartridge head.



- Make sure that there are always adequate number of electrode caps in the cartridge to avoid initial filling!
- Use an auxiliary tool to position the electrode cap in the cartridge removal unit (removal position)!



- Do not insert your finger in the spring-loaded separation unit!
- When inserting the quick-change cap cartridge in the cartridge head, pay attention to see that your finger does not get caught between the cartridge and the cartridge head!
- When inserting the cartridge with an empty cartridge head, you must pay attention to see that your finger does not get caught in the cartridge removal unit while electrode caps are being fed via the spring-loaded compressing piece from the cartridge shaft!

6.5.1 Filling operation

The shafts of the quick-change cap cartridge must be filled up with electrode caps by one of the two options described below.

ATTENTION



Damage to the machine by using unapproved or damaged electrode caps

There are risks if damaged electrode caps or electrode caps with residual seam are fed to the quick-change cap cartridge and these then get jammed or blocked in it.

- The permissible cap contour for the electrode cap cartridge is engraved on the side of the changer cartridge. The contours of the electrode caps must match those of the cap-filling shaft.
- The abbreviated designation of the electrode caps to be used is located on both sides of the cartridge head (e.g. F16/20 for caps of the shape F, diameter 16 mm, length 20 mm).
- Electrode caps must have sufficient wear pattern (adequate residual thickness of the copper). For pulling out the electrode caps safely, they should have a minimum length of approx. 8 mm near the complete outer diameter.
- Use only burr-free and undamaged electrode caps.

Option 1

1. Press in the electrode caps one after another against the spring pressure of the compressing piece in the cartridge shaft until the engraved marking.
2. Unlock the locking pin after completing the filling.
3. Insert the quick-change cap cartridge into the cartridge head that is also filled with electrode caps until it latches audibly.
4. Close the tension lock with the safety clip.

Option 2

1. Press the spring-loaded compressing piece back into the cartridge shaft until the locking pin latches into the compressing piece.
2. Push the electrode caps one after another into the cartridge shaft up to the engraved marking.
3. Unlock the locking pin after completing the filling.
4. Insert the quick-change cap cartridge into the cartridge head that is also filled with electrode caps until it latches audibly.
5. Close the tension lock with the safety clip.



6.6 Switching off the machine

The machine has a main switch as an option and is shut down with the help of this switch or it must be integrated in the control concept of the overall system.

6.7 Restarting after occurrence of a fault

Once a fault has occurred, the machine should be restarted only after the cause of the fault has been rectified by qualified personnel.

WARNING

Risk of injury due to unauthorized restart following a fault

There are hazards if the machine is restarted by persons without authorization following an occurrence of a fault.

- Only authorized qualified personnel with appropriate authorization are allowed to put the machine back into operation and only after rectifying the cause of the fault!
- Ensure that nobody is present within the danger zone of the machine at the time of restart, and that all work of fault rectification has been completed!

7

Decommissioning

7 Decommissioning

In this section, you will learn about the steps needed for putting the machine out of operation and for storing it.

NOTICE



Observe the safety instructions

In addition to the safety instructions included in this chapter, all warnings and warning icons on the machine must be observed!

7.1 Decommissioning and storing the machine

If the machine is taken out of operation for a longer period of time (> 2 weeks), this is termed 'decommissioning'. When decommissioning the machine and possibly storing the machine components, the measures for storage described in the following need to be adopted.

Decommissioning

1. Put off the machine at the main switch (optional fitting)!
2. Disconnect all energy supplies and equipment supply lines between the connections and the machine components!

DANGER



Danger to life due to remaining energies when disconnecting the energy supplies

When decommissioning the machine, while disconnecting the energy and operating materials connections, residual energy may get released, which may result, among others, in sudden machine movements!



- The machine should be decommissioned only by authorized qualified personnel who have received special training and are very familiar with the machine!
- Wear personal protective equipment!

WARNING



Risk of injury and damage to the machine as a consequence of tilting or falling down when stored incorrectly

There is the risk that the machine components may tip over or fall if they are stored incorrectly.



- Secure the machine against unintended tipping over and instability!
- Observe the center of gravity of the machine components!
- Reducing the risk of tipping over by shifting the center of gravity of the machine components, downwards by reducing the working height using the height adjusting mechanism!
- Use personal protective equipment!

7.2 Decommissioning and disposing of the machine

When the machine has reached the end of its service life, it is decommissioned permanently and prepared for disposal. When dismantling the machine, safe and professional disposal must be ensured, in particular with regard to the parts or substances that are harmful to the environment. This includes, among others, the chemicals, grease and lubricants, plastics used, as well as batteries, if any.

The disposal of the machine is governed by the local regulations on disposal, as well as the environmental protection laws applicable in the user's country.

ATTENTION



Environmental hazard due to incorrect disposal

There are hazards due to dangerous materials or substances being released into the environment if the machine components, equipment and hazardous substances are not disposed of professionally.

- Have the machine disposed of only by an approved and specialized company!
- Packaging material, machine components and operating materials (among others oils, greases and lubricants. Preservation agents) must be disposed of in accordance with the environmental conservation laws applicable in the user's country (Location)!

8

Setup Tool Installation

8 Setup and Tool Installation

This Chapter contains information on how to disassemble and assemble the spare parts and wear parts of the machine. For the setup operation, in case of change in type, the replaceable tools are setup parts are display in a tabular manner and described.

NOTICE



Observe the safety instructions

In addition to the safety instructions included in this chapter, all warnings and warning icons on the machine must be observed!

8.1 General safety instructions »Setup and tool installation«

WARNING



Risk of injury when doing setup work with the machine switched on

For setup and fitting work, there is the risk of suffering serious injuries between force-actuated (electrical) machine components (especially drives) and by open crushing and shearing edges.



- Before commencing setup and fitting work, the machine must be shut down! Put the main switch (optional fitting) in the electrical switch box to the »0/OFF« switch position!
- In addition, the power supply must be interrupted by pulling out the power supply connector of the machine!
- Component replacement should be carried out only by trained setup personnel!
- Wear personal protective equipment!

ATTENTION



Constructional modifications

No modifications, attachments or conversions should be made on the machine without the consent of the manufacturer. This is particularly applicable to making bore holes or welding on load-bearing parts.

- All conversion measures require written confirmation from Bräuer Systemtechnik GmbH!
- machine components – especially safety and protective equipment – not in proper condition must be replaced immediately!
- Use only original spare and wear parts!

8.2 Tool change

8.2.1 Replacing the electrode cap changing head (Service)

Because of the impact of adhesive and contamination, which are possibly flushed in by residual cooling water, there may be blockages in the changing head.

The cause of faults must be eliminated and the complete function of the cap changing head must be restored.

The electrode cap changing head is selected depending on the cap diameter. In line with DIN EN ISO 5821 »Resistance welding - point welding-electrode caps« changing heads are available for cap diameters of 13, 16 and 20 mm as standard.

8.2.1.1 Disassemble the electrode cap changing head

- Make sure that the machine is switched off and secured against being put back into operation.
- Disable the relative brake. Use the cylindrical head screw M4x12: screw it in – pull it back – tighten.

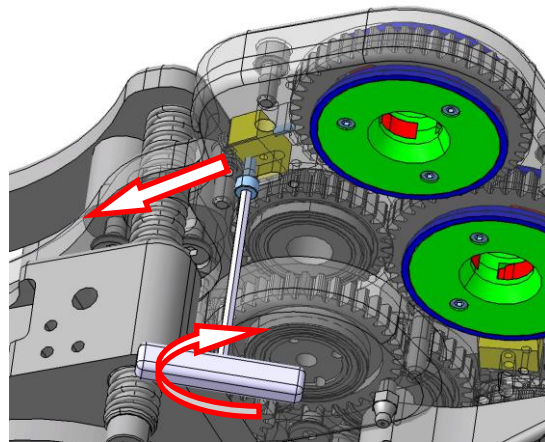

- Unscrew cylindrical head screws M3x10, starting from below. Attention - hold parts in place!

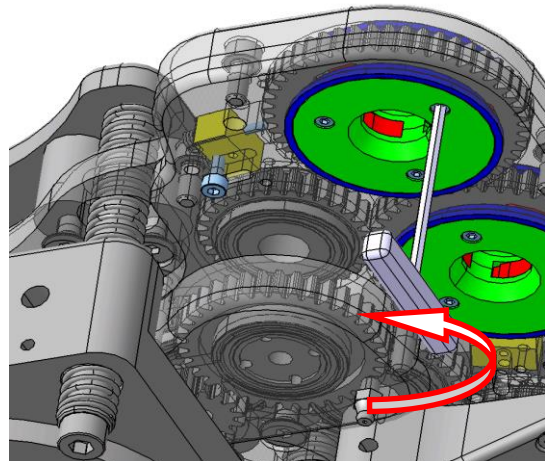

Setup and Tool Installation



- Unscrew the cylindrical head screws M3x10. Attention! Hold the parts!
- Remove the cylindrical head screws and the »top bushing«.

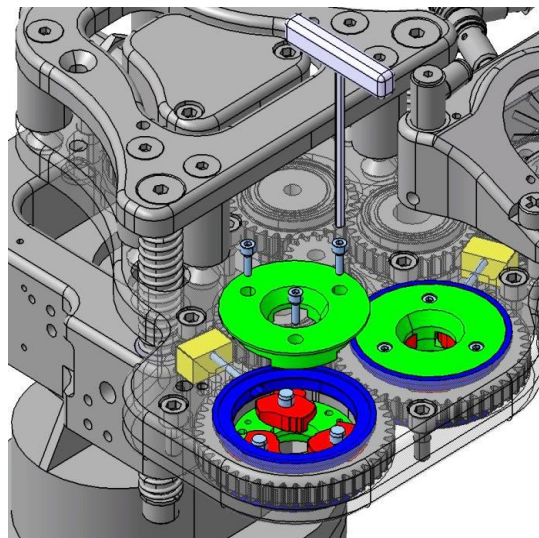

- Remove 3 cylindrical pins. Attention! Hold the parts!

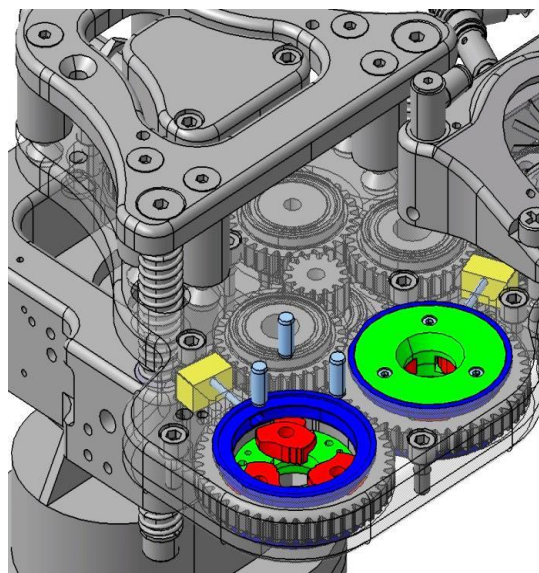

- Remove the jaws. Attention! Hold the parts!

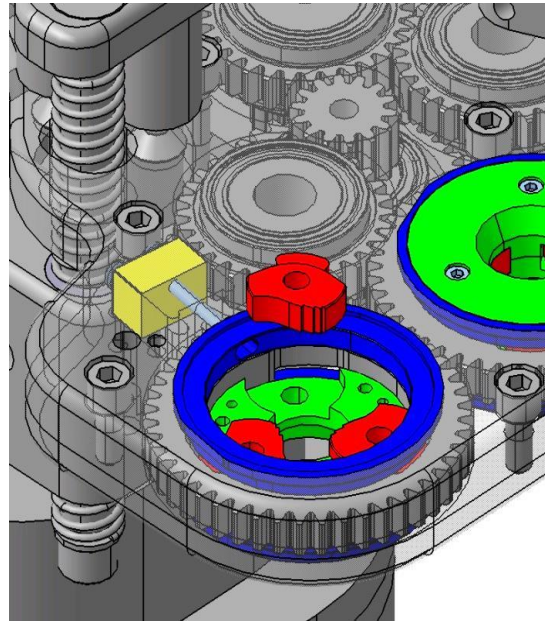

- Remove the »bottom bushing«.

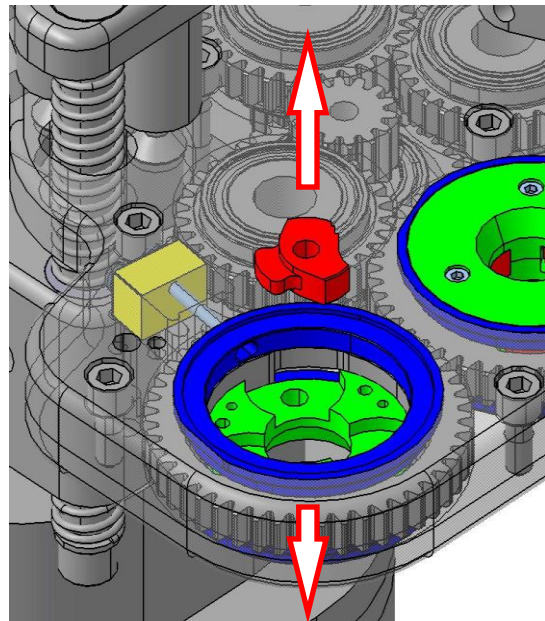

8.2.1.2 Assemble the electrode cap changing head

ATTENTION



Lubricate the friction bearing

Recommended lubricant for the friction bearing of the changing head:

- high-pressure resistant adhesive lubricant oil HHS 2000

- Clean the parts, check for wear (replace worn parts).
- Check for ease of movement of the relative brake prior to installation.
- Assembly takes place in the reverse order of the disassembly.
- Observe the installation direction of the jaws depending on the direction of rotation (► Chapter 6.4.1)!

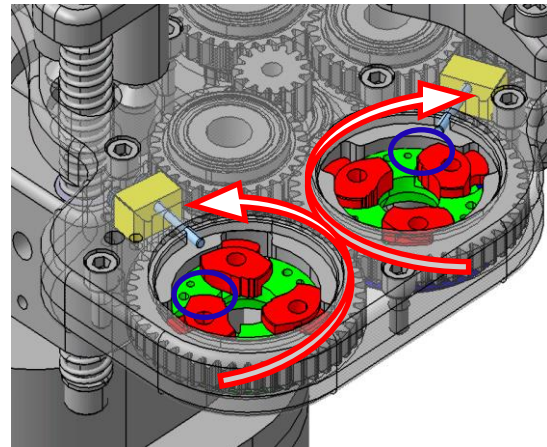

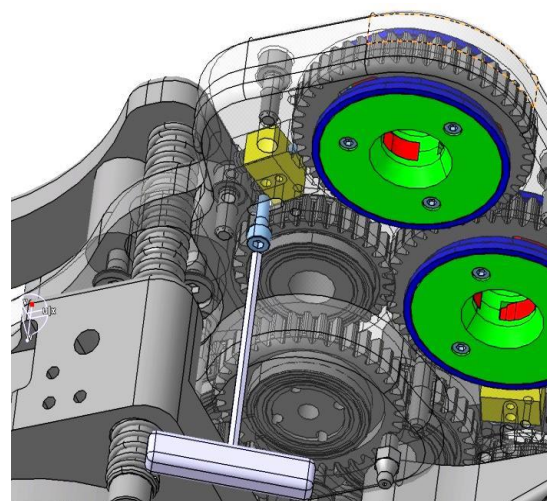

- Release the relative brake again so that it is effective.
- Remove the cylindrical head screw M4x12.



8.3 Restarting after retrofitting

WARNING

Risk of injury due to unauthorized restart following reconfiguration

There are hazards if the machine is put into operation by persons without authorization following a reconfiguration.

- Only authorized specialists with appropriate authorization are allowed to put the machine back into operation and only after the reconfiguration has been completed!
- Ensure that nobody is present within the danger zone of the machine at the time of putting it back into operation!

9

Maintenance Service

9 Maintenance and Service

This Chapter contains information on how to maintain the functionality of the machine by cleaning and by professional and timely maintenance, and on how to reduce the chance of a failure.

NOTICE



Observe the safety instructions

In addition to the safety instructions included in this chapter, all warnings and warning icons on the machine must be observed!

NOTICE



Technical support by the manufacturer

For technical assistance in maintenance and servicing work, contact Bräuer Systemtechnik GmbH!

WARNING



Risks posed by automatic start-up of the machine

While doing maintenance and adjustment work on moving machine components, you may suffer crushing injuries or cuts near your fingers.

There are risks posed by electrical, mechanical, and thermal energy sources as well as residual risks (stored energy) on the machine.



- Maintenance work should be done only if the machine is shut down and secured against being switched on again!
- Start the maintenance work only when heated up components have cooled down!
- Do not start maintenance work until dangerous movements caused by stored energy are no longer possible!
- Maintenance work should be carried out only by authorized machine configurators trained for this purpose!
- Always use suitable tools for all maintenance and repair work!
- Before putting the machine into operation, the personnel must satisfy themselves by visual inspection that nobody is inadvertently present in the danger zone or is reaching into it!
- Observe the danger zones and hazard warnings at the machine !
- Never reach in between moving parts or actuators!

WARNING

 **Dangers due to failure to use the personal protective equipment**

There are health hazards if appropriate protective clothing corresponding to the task is not worn while doing maintenance, repair or cleaning work.



- Personal protective equipment must be worn for maintenance, repair and cleaning works without exception!
- Observe the accident prevention regulations and work instructions!

9.1 Preparatory works



In order to be able to perform maintenance, servicing and cleaning work safely for human being and the machine, the work needs to be specified in advance and the machine needs to be prepared. The switch-off procedure described in the following must be performed in the prescribed order for all maintenance and cleaning work on the machine.

1. De-energize the machine electrically.
2. De-energize the machine pneumatically.
3. Secure the machine against being switched on again
4. Determining the electrical de-energization.
5. Ground the machine and short circuit it.
6. Cover / Cordon off adjacent, live parts.
7. Place a warning against putting on the machine at an appropriate location.

WARNING

 **Risk of injury due to residual energy**

During maintenance work, there may be unforeseeable dangerous situation of any type that occur.

- The work of maintenance, servicing and repair should be done only by trained or instructed specialists!
- Before carrying out the maintenance work, the machine has to be shut down and secured!
- Create additional safety by pulling out the power supply connector of the machine!
- Personal protective equipment must be worn!

9.1.1 Repair shipping

When determining damage to the machine, which cannot be repaired independently, contact the customer service (Service) of the manufacturer of the machine, Bräuer Systemtechnik GmbH.

If unit components that require repair or maintenance are shipped to the manufacturer, such components must be packaged securely.

- Use bubble wrap, foam cushion packaging or cardboard and other packaging material so that damage to the components during transport due to external effects is prevented.
- Secure parts during against accidental tilting and instability during transportation.

9.2 Cleaning and Care

The machine, the machine components and the workstations of the personnel must be cleaned at regular intervals so as not to jeopardize the safety at the machine and the machine functionality. In case of particularly high level of contamination or pollution with dirt, the machine needs to be cleaned more frequently.

9.2.1 Cleaning work

The requirement for carrying out cleaning work is preparation of the machine (► Chapter 9.1).

ATTENTION



Danger of injury due to disregard of manufacturer's instructions

The function of the machine may be impaired by ignoring the cleaning instructions of the manufacturer.

- Comply with all environment conservation regulations applicable when cleaning.

ATTENTION



Damage to the machine caused by liquids/media

With the entry of water or cleaning agents into the machine or in electronic assemblies and modules, there is the danger of damage to the machine. The items most endangered include electrical motors, sensors and the electrical switch box.

- Before cleaning the machine, all openings must be covered in which no water/steam/cleaning agent should penetrate for the sake of safety and/or functionality!

The following aids and tools are suited for removing coarse and loose dirt:

- Clean broom, hand brush, clean (paint) brush
- Vacuum cleaner, compressed-air pistol
- Soft lint-free cloth

NOTICE



Damage of components in the machine by using metallic tools or objects when cleaning the machine

Using metallic tools or objects when cleaning the machine may lead to components of the machine getting damaged (e.g. cables or lines).

- Do not use any metallic objects or tools for cleaning the machine or its components!

WARNING



Injury hazard and property damage due to the incorrect application of cleaning agents

If the manufacturer's cleaning instructions are not observed, the use of cleaning agents may result in injuries, health complaints and damage to the machine.



- Do not use any corrosive cleaning agents (acetone, nitrous dilution)! Use cleaning agents in compliance with the manufacturer's instructions!
- Whenever work is carried out with operating fluids (oil, cleaning fluids, etc.), the special operating and work instructions, or the relevant safety data sheets, must be observed when handling such substances!
- Suitable protective clothing must be worn for all cleaning work!
- Cleaning works are to be performed by qualified personnel!
- Use a halogen-free cold cleaner with a high flash point for cleaning!

WARNING



Injury hazard due to ejected dirt

For cleaning work with compressed air, dust or cleaning agents may get swirled up and fly about under high pressure. The consequence may be injuries to the eyes.



When cleaning with compressed air, pay attention to suitable extraction and personal protective equipment such as safety goggles, protective overalls etc.



- Never clean persons or body parts with compressed air or high pressure! Always point the compressed air stream away from you and others!
- You must wear safety goggles when cleaning!

ATTENTION



Environmental conservation

When cleaning and caring for the machine, waste products occur, which should not reach the general waste or in purification plants. Waste oil, used grease and chemicals are special waste and must be disposed of in accordance with country-specific provisions.



- Ensure that grease and other harmful substances are not released into the sewer system!
- Collect used oil and other substances that are harmful to the environment! They must be disposed of professionally in compliance with the regional provisions and environmental protection regulations!
- Dispose of replacement parts safely and by conserving the environment!

ATTENTION



Damage to the bearings and gear unit caused by improper cleaning

When blowing off the machine with compressed air, swarf and dirt particles may penetrate the bearings and gear unit and damage them.

- Cover the bearings and gear unit before starting the cleaning work and thus protect them from coming into contact with water and dirt deposits!

9.2.2 Finishing the cleaning work

1. After cleaning, the additional covers/adhesion applied before carrying out the cleaning must be removed again completely!
2. All lines and hoses must be examined for leaks, loose connections, chafe marks and damage! Any defects noticed must be rectified immediately!
3. After completing the cleaning work, all devices and aids used must be removed from the vicinity of the machine!
4. Check the functions of the cleaned area!

9.3 Maintaining the pneumatic equipment





If hoses, valves or connecting points of the pneumatic components have breakages, cracks, frayed or brittle spots etc., they must be replaced immediately by qualified personnel. The machine must be shut down and brought to standstill until it is rectified.

Check pneumatic hose lines at reasonable intervals for bends and cracks and replace them where necessary!

Checking the pneumatic components

- Visual inspection of fastening of joints and connections
- Replace frayed or brittle hoses
- Tighten loose hoses
- Replace bent hoses or lay them again

WARNING



Risk of injury due to compressed air

In the course of establishing pneumatic connections, when the hose connection becomes loose due to a faulty connection or connector, or the input pressure gets too high, there is a risk of compressed air leaking from the loose connection or equipment under high pressure. The end of the hose moves uncontrollably and may cause severe eye injuries.

When pressurizing or depressurizing the pressurized machine components hazards may occur due to unexpected movement of pressurized supply lines.

- Work on the pneumatic systems should be performed only by qualified personnel with special knowledge and experience in pneumatic systems!
- Before working on pressurized systems and assemblies, switch off the compressed air supply at the main valve of the supply and secure the condition! The pressure drop is to be monitored on the manometer!
- Never open the system when it is pressurized! Consider potential remaining energy in the pneumatic actuators!
- Personal protective equipment is to be worn when working at pressurized systems!

9.4 Maintaining the electrical equipment



If connectors, cables or other electrical components have breakages, cracks, frayed or brittle spots etc., they must be replaced immediately by qualified personnel. The machine must be shut down and brought to standstill until it is rectified.

All the switchgear necessary for operating the machine is installed in the electrical switch box.

Checking the electrical system

- Visually inspect the cables and connectors
- Replace frayed cables
- Tighten loose cables
- Replace contactors with singed or scorched contacts

DANGER



Danger to life due to electric shock in the event of contact with energized electric devices due to human error or lack of qualification

Touching live conductors or components that carry the intended voltage, or in case of contact with live conductors or components that carry voltage in faulty condition (in particular due to insulation faults), as well as due to electrostatic processes such as touching statically charged components, may result in danger to life due to electrical shock!

There is a risk of fire, electric shock, burns and death if people approach live components, especially in the high voltage area.

After switching off the machine, remaining electric energy still resides in the lines, devices and components for approx. 5 minutes.

The electrical switch box contains live parts. Opening the door of the electrical switch box may cause death, serious injuries or damage to property caused by electric shock. The main feed terminals are energized, even if the main switch is turned off.

Non-compliance (such as freely accessible contacts, incorrect installation of the earth line, etc.) can result in electric shock and ultimately in the most severe injuries (cardiac arrhythmia, severe burns, blindness) and death!

- Observe a safety clearance around energized cables and avoid contact with them under any circumstances!
- Have work at the electric supply or at freely accessible energized devices performed only by qualified electricians and with the power switched off! Disconnect the machine from the main power supply and secure against unintentional restart, if running parts of the machine can be accessed using tools.
- Keep the electrical switch box locked at all times! Intervention is permitted for authorized personnel only!
- Check the electrical equipment of the machine at regular intervals (inspection (every 4 years in accordance with DGUV REGULATIONS 3)! Replace singed or scorched cables! Inspect insulation of all moving cables for damage at regular intervals during repair and maintenance works! Eliminate loose connections!
- Regular safety briefings with the operating personnel about the risk of the remaining power.

9.5 Lubrication

9.5.1 Lubricating the gear unit

After doing repair work, the gear unit must be lubricated again with the lubricant »Staburags NBU 12 (made by Klüber) «.

1. With the help of a grease gun, apply approx. 35 gm (35 ml) of the lubricant in the gear wheel spaces that are still empty in the »top plate« of the gear unit!
2. Lubricate the gear unit quarterly with approx. 10 g (10 ml) of lubricant!

ATTENTION



machine damage due to insufficient lubrication of the gear unit

- Make sure to observe the lubrication intervals of the gear unit!

ATTENTION



Danger of environmental pollution/contamination

Ensure that grease and other harmful substances do not reach the environment.



- Collect used grease and other substances that are harmful to the environment!
- Dispose of them properly and professionally!

9.6 Maintenance plan

The following general maintenance tasks must be performed professionally and in a timely manner. If the required steps are more complex, the maintenance plan will refer to the technical documentation of the manufacturer of the machine components as well as the separate maintenance plan.

The requirement for carrying out the following maintenance and cleaning work is the preparation of the machine as described in chapter ► 9.1.

NOTICE



Maintenance instructions Maintenance plan/Supplier documentation

In addition to the general tasks listed in the following maintenance plan, observe the maintenance and cleaning instructions of the relevant supplier documentation!

- Detailed maintenance tasks are provided in the separate document »Maintenance instructions and spare parts list«! This maintenance plan is given in the Appendix to this operating manual.
- An overview of the supplier documentation is provided in
► Chapter **Fehler! Verweisquelle konnte nicht gefunden werden..**

Maintenance and cleaning works according to the maintenance plan must be recorded in a log. For this purpose, the following pages contain templates of the maintenance plan (to be used as master copy), in which the maintenance task as performed is signed off at the end of the respective line.

Maintenance work that is not described in this instruction manual or in the supplier documentation must be performed only after consulting Bräuer Systemtechnik GmbH.

All the intervals mentioned in the following are merely recommendations by Bräuer Systemtechnik GmbH! Depending on the operating conditions, the intervals for maintenance and cleaning work must be adjusted accordingly.

We strongly recommend that the company operating the machine document observations that are relevant with regard to maintenance, and that it supplements, as well as specifies, on its own accord, the maintenance plan of this operating manual accordingly by issuing an operating instruction!

9.6.1 Maintenance plan - Qualified personnel

Competence: Specialists		Interval: daily
No.	Maintenance work to be performed	Measures
1.	Checking the machine for externally identifiable defects or damage	<ul style="list-style-type: none"> • If required, rectify the defects with qualified personnel before putting the machine into operation! • Carry out a functional test prior to normal operation!
2.	Visual inspection and functional testing of the safety cover of the electrode cap cartridge	<ul style="list-style-type: none"> • Perform a visual check of the plastic covers! • Replace these, if necessary, prior to putting the machine into operation!
3.	Checking the movement-related fastening of the cabling of the equipment and signal encoders	<ul style="list-style-type: none"> • If necessary, fasten the cable again with the help of cable binders or similar (to avoid premature cable breakage)!
4.	Checking the stability of the machine	<ul style="list-style-type: none"> • Retighten the fastening of the machine to the machine building floor or replace it!
5.	Clean and clear up the workplace	<ul style="list-style-type: none"> • Use appropriate cleaning agents for cleaning taking the ignitability of the respective cold cleaner into consideration!
6.	Visual inspection of mechanically movable machine components for ease of movement	<ul style="list-style-type: none"> • Check the movable components of the machine accordingly! • Make setting and/or adjustments if necessary!
7.	Visual inspection of the changeable heads for dirt or contamination	<ul style="list-style-type: none"> • Check the changeable heads for dirt or contamination by swarf or welding beads! • Remove the swarf from the changeable heads, if required, with an appropriate tool (tweezers)!

Competence: Specialists		Interval: weekly
No.	Maintenance work to be performed	Measures
1.	Checking the drives for irregular noises!	<ul style="list-style-type: none"> • Check for noises by listening to the drive! • If required, clean the cooling fins with a brush!

Competence: Specialists		Interval: quarterly
No.	Maintenance work to be performed	Measures
1.	Check the pneumatic system for leaks, corrosion and damage.	<ul style="list-style-type: none"> • Check the components of the pneumatic system for functionality! • If necessary, replace the hose clamps, hoses and fine filters! • If required, readjust the operating pressure!
2.	Checking the screw and clamp connection	<ul style="list-style-type: none"> • Check all screws and clamp connections for a tight fit! • Replace them or tighten the screw connections again!
3.	Checking the cable routing of the sensors, plug-in connections	<ul style="list-style-type: none"> • Check all cables and connections for breaks, damage and dirt or contamination! • Replace them if necessary! • Clean them if necessary!
4.	Cleaning the sensor surfaces	<ul style="list-style-type: none"> • Clean the surfaces of the proximity switches with a non-corrosive cleaning agent!
5.	Checking and cleaning the electrical switch box	<ul style="list-style-type: none"> • Check the electrical switch box for humming! • Perform a visual inspection of the cable connections and the main supply! • Replace the electrical components if necessary! • Clean the electrical switch box inside, if necessary, with the help of a vacuum cleaner! • Have an expert inspection performed on the electrical equipment at least once every 4 years!
6.	Checking for the presence of all safety signs and warnings	<ul style="list-style-type: none"> • Perform a visual check! • Replace missing or illegible symbols and information signs if necessary!
7.	Lubricating the gear unit	<ul style="list-style-type: none"> • Lubricate the gear unit with approx. 10 gm (10 ml) of lubricating grease Staburags NBU 12 (from Klüber) with a brush! With a large amount of water coming up the lubrication interval must be reduced! • Always lubricate even after doing repair work!

9.7 Manufacturer service

For technical assistance concerning the performance of maintenance, servicing, repair and cleaning work, contact the customer service of Bräuer Systemtechnik GmbH!

NOTICE



Service address

Bräuer Systemtechnik GmbH
Gewerbegebiet Nord 6
09456 Mildenau
Germany
Telephone: +49 (0) 3733/5967610
Fax: +49 (0) 03733/5967611

9.7.1 Spare parts ordering

The necessary spare parts and wear parts lists are provided in the Appendix to this Installation Manual. To place an order, the following information is required:

- Material or drawing number
- Component description
- Dimensional specifications
- Quantity

ATTENTION



Damage to the machine by using spare parts that are not approved

Inferior quality components may impair the safety of the machine. Only original spare parts supplied by the manufacturer are covered by the warranty.

For loss or damage that occurs by using improper or unsuitable parts and accessories, any liability or warranty on the part of the manufacturer is ruled out.

- In order to ensure proper functionality and operational safety of the machine, only those spare parts and wear parts approved by the manufacturer should be used!
- When replacing machine parts, which serve to safeguard the safety of the machine, only original parts or equivalent standard parts should be used; in order words, those which exhibit the same safety standards.

9.8 Finishing the maintenance work

The following checks need to be carried out to be able to put the machine safely into operation after doing maintenance or cleaning work on it.

- Check the protective ground conductor connections for tight fit.
- The necessary work has been carried out in accordance with the maintenance plans.
- Re-install all dismantled labels and signs following the replacement of cables, lines and equipment!
- Always tighten loose screws when performing service and maintenance work.
- Check for the presence as well as the functionality of the safety/protective devices.
- When the work has been completed, remove all tools, bolts, aids or objects from the working area of the machine!
- Lock the electrical switch box again and hand over the key to the person responsible.
- Carry out a functional test (trial run) after completing maintenance and repair work.

WARNING



Risk of injury resulting from unexpected start-up of the machine components following a restart

There are hazards caused by clothing getting entangled and pulled in if the machine starts up unexpectedly while putting it back into operation after doing maintenance and cleaning work on it.



- All safety equipment must be checked for their proper functionality every time the machine is maintained or repaired!
- Restart only with completely mounted safety devices and safeguards!
- Ensure that nobody is present in the danger zone or is reaching into it at the time of putting the machine back into operation!

ATTENTION



machine damage caused by foreign bodies in the machine

During maintenance work, foreign bodies such as dirt or contamination, tools or loose components such as screws etc. could remain in the machine. This may result in collisions, short circuit or increased noise levels. The machine may get damaged.

- After completing the maintenance work, pay attention to see that no foreign bodies remain in the machine!
- Fasten loose components again after completing the maintenance work!
- Remove dirt or contamination carefully!

10

Faults

10 Faults

This section describes potential faults that may occur in the machine. In addition, it includes a summary of the procedure in a fault situation, as well as safety notices for fault location.

NOTICE



Observe the safety instructions

In addition to the safety instructions included in this chapter, all warnings and warning icons on the machine must be observed!

NOTICE



Technical support by the manufacturer

For technical assistance in fault rectification, contact Bräuer Systemtechnik GmbH!

WARNING



Injury hazard due to human error or lack of qualification

There are hazards due to human error when faults have occurred, or during their elimination.



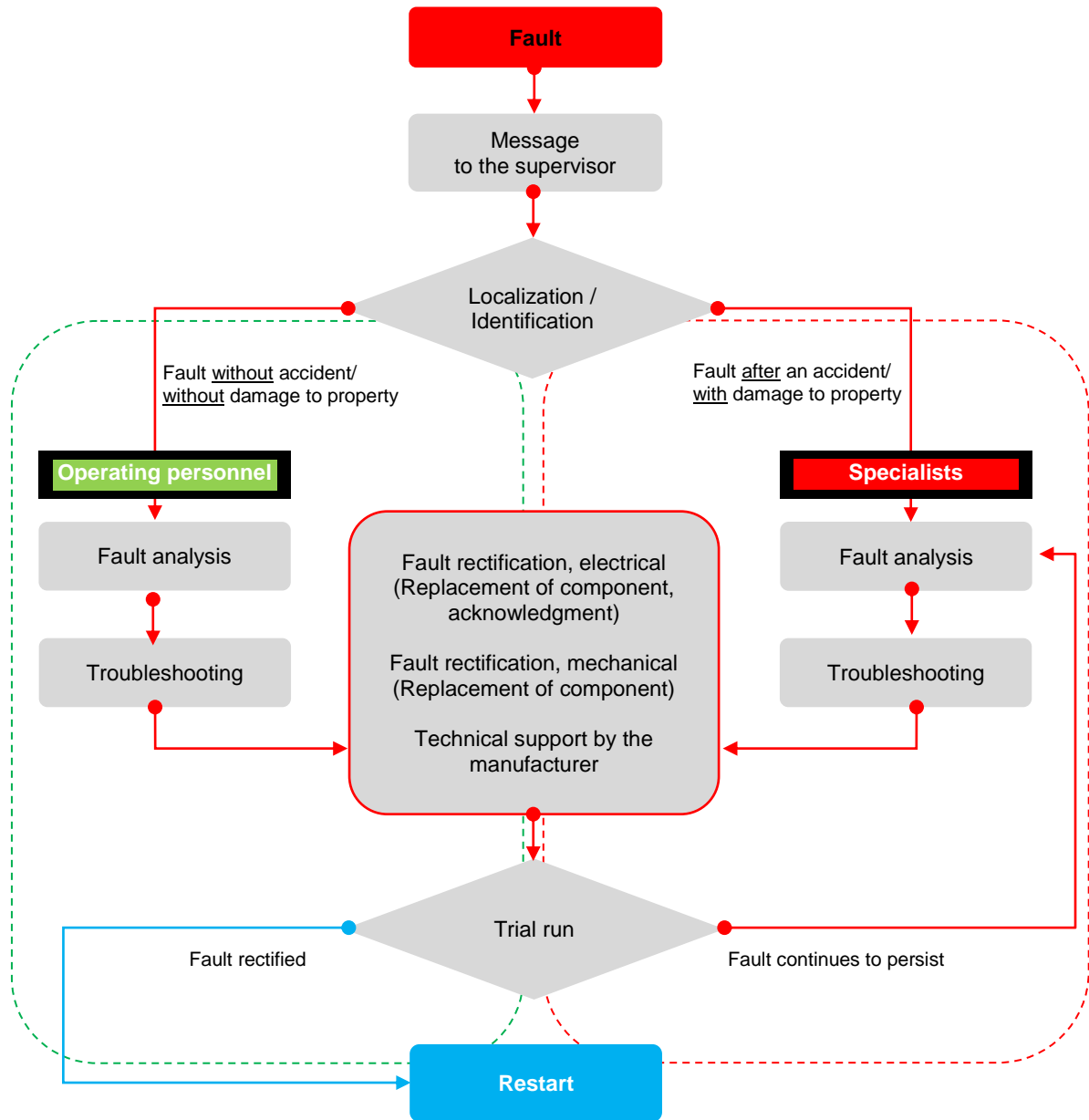

- When a fault occurs, the machine must be shut down and secured, and qualified personnel must be informed!
- The analysis and rectification of faults should be done only by qualified personnel who have received special training and are very familiar with the machine!
- In the event of faults reoccurring, qualified personnel must be informed without delay!
- The operation is forbidden in any case in the presence of obvious faults!
- Contact the manufacturer if the fault cannot be eliminated by the operator's own qualified personnel!

10.1 Procedure for malfunctions



10.2 Troubleshooting

DANGER





Danger to life during fault rectification on machine components that have become defective

Any changes compared to normal operation, e.g. higher power consumption, temperatures or vibrations, unusual noises or odors, etc. identify that the function is impaired. Faults may occur that may lead directly or indirectly to death, serious injuries or damage to property.

- Notify the maintenance personnel!
- Shut down the machine immediately by observing the machine-specific safety conditions!
- Never remove jammed workpieces or foreign objects with your bare hand! Use suitable aids (e.g. tweezers)!
- Work on the machine with safety and protective equipment switched off or dismantled should be carried out only by qualified personnel who have been specially trained and are very familiar with the machine!

DANGER

Danger to life by intervening in the danger zone



There is danger to life if you reach into or walk in the direct area of action of a defective machine

- If individually moved components come to standstill without any apparent reason, you should reach into the danger zone after the machine has been shut down and disconnected from the power supply!
- Have the work of troubleshooting and fault rectification done by qualified personnel!
- Put the machine back into operation only if safe and fault-free operation can be guaranteed!

10.3 Restarting after fault rectification

When the fault has been rectified, the machine can be put back into operation and handed over to the operating personnel.

WARNING

Risk of injury resulting from unexpected start-up of the machine components following a restart

There are hazards caused by clothing getting entangled and pulled in if machine components start up unexpectedly while restarting the machine following successful fault rectification.

- Increased caution is required when working while safeguards are unlocked or dismantled!
- Restart only with completely mounted safety devices and safeguards!
- Ensure that nobody is present in the danger zone or is reaching into it at the time of restart!

11

Appendix

11 Appendix

11.1 Index

A	
Airborne sound.....	4-3
Altitude.....	5-9
Ambient temperature	5-9
Assembly	5-8, 5-12
Atmospheric humidity.....	5-9
B	
Base.....	4-3
Base frame	4-23
C	
Care	9-3
Cleaning.....	9-3
Cleaning work.....	9-3
Conduct in case of a fire or accident.....	3-3
Connection socket of the power supply	4-8
Contamination.....	5-9
Control elements.....	6-3
Copyright	3
D	
Dangers due to mechanical energy	3-12
Dangers from electric energy	3-10
Dangers posed by pneumatic energy	3-13
Decommissioning.....	7-1, 7-2
Disposal	7-2
Drive unit.....	4-16
Duties of the personnel.....	3-7
E	
Electrical control cabinet	4-7
Electrical equipment.....	4-6
Electromagnetic compatibility.....	4-3, 5-9
Emergency situations.....	3-3
Energy supplies	5-14
Environmental conservation.....	5-7, 9-5
Erection.....	5-8
Ex protection	5-9
F	
Faults	10-1
Fire prevention symbols.....	11-7
Frequency.....	4-3
Further applicable documents.....	2-2
Further applicable documents.....	2-2
Fuse.....	4-3
G	
General information	2-1
H	
Hazard symbols.....	11-7
Hazards due to emissions	3-15
Height adjustment mechanism	4-23
I	
Identification	1-1
Improper use	1-4
In the event of fire.....	3-3
L	
liability.....	2-1
Lubrication.....	9-8
M	
Maintenance instructions and spare parts list.....	9-9
Maintenance plan	9-9
Maintenance schedule »Qualified personnel«	9-10
Mandatory signs	11-6
Manufacturer service	9-12
Motor circuit breaker.....	4-8
Motor nominal speed (rpm)	4-3
N	
Noise	3-15
Nominal current	4-3
Number of phases	4-3
O	
Operating and ambient conditions.....	5-9
Operating personnel	3-5
Operating voltage	4-3
Operator obligations	3-6
Other symbols	11-8
P	
Personal protective equipment	3-7
Personnel qualification	3-5
Power / On time.....	4-3
Preparing for maintenance	9-2
Procedure for malfunctions.....	10-2
Prohibition symbols	11-4
Proprietary notice	3
Protective covers.....	4-4
R	
Release date	3
Repair shipping	9-3
Rescue symbols	11-8
Residual dangers	3-8

Restarting	6-11, 8-6, 10-3
Risks posed by cleaning agents.....	3-16
Risks posed by lubricants	3-17
Risks posed by the operating materials	3-16

S

Safety.....	3-1
Safety controls	3-2
Safety devices.....	4-4
Safety notices	
Structure and visualization	3-2
Safety symbols	
DIN EN ISO 7010	11-3
Safety-oriented behavior	3-4
Service life	1-1
Setting up the machine	5-11
Shutdown procedure.....	9-2
Spare parts	9-12
Specialists.....	3-5
Start-up	6-4, 6-7
Storage	7-1
Structure of a safety notice	3-2
Switching off the machine	6-11

T

Tasks of the personnel.....	6-2
-----------------------------	-----

Technical support	9-1, 10-1
Testing the electrical equipment.....	9-7
Tool change.....	8-2
Transmission	9-8
Transport with a forklift	5-2
Transportation procedure	5-2
Troubleshooting.....	10-3
Type of power connection	4-3

U

Unpacking the machine	5-4
-----------------------------	-----

V

Visual inspections.....	6-7
Voltage fluctuations	4-3

W

Warning levels.....	3-2
Warning symbols.....	11-4
Warranty.....	2-1
Weight	4-3
Work, service and protected areas	5-9
Workstations.....	6-2



11.2 Safety symbols (DIN EN ISO 7010)

The following special safety symbols in accordance with DIN 48447010 are used at the corresponding passages in the text of these operating instructions Installation Manual and require special attention depending on the combination of signal word and symbol:

11.2.1 Warning symbols

	General warning sign		Warning - Toxic substances
	Warning - Explosive substances		Warning - Hot surfaces
	Warning - Radioactive substances or ionized radiation		Warning - Automatically starting machinery
	Warning - Laser radiation		Warning - Crushing danger
	Warning - Non-ionized electromagnetic radiation		Warning - Flammable materials
	Warning - Magnetic field		Warning - Corrosive substances
	Warning - Obstacles on the ground		Warning - Risk of hand injuries
	Warning - Danger of falling		Warning - Danger of rolling in opposite directions
	Warning - Biohazard		Warning - Risk posed by charging batteries
	Warning - Low temperature / Frost		Warning - Optical radiation
	Warning - Slip danger		Warning - Oxidizing substances
	Warning - Hazardous electrical voltage		Warning - Gas cylinders
	Warning - Fork lift trucks		Warning - Explosive atmosphere
	Warning - Suspended loads		

11.2.2 Prohibition symbols









	General prohibitory sign		Do not reach inside
---	--------------------------	--	---------------------

	No smoking		Climbing prohibited
	Naked flames, fire, expose ignition sources and smoking prohibited		Eating and drinking prohibited
	Pedestrians are not allowed		Depositing or storing objects is prohibited
	Not drinking water		No access
	Prohibited for industrial trucks		Using gloves is prohibited
	Entry prohibited for those with pacemakers or implanted defibrillator		Operating is prohibited
	Do not touch		Spraying with water is prohibited
	Extinguishing with water is prohibited		Unauthorized access is prohibited
	Heavy loads are prohibited		Unauthorized climbing is prohibited
	Turn of all mobile phones		Entry for persons with metallic implants prohibited









11.2.3 Mandatory signs

	General mandatory sign		Wear protective headgear
	Follow the operating instructions		Use a warning vest
	Use ear muffs		Wear a mask
	Wear eye protection (safety goggles)		Wear inhalation protection
	Ground before use		Use a safety harness
	Remove the power plug		De-energize prior to maintenance and repair
	Wear safety boots		Use the crossover
	Wear protective gloves		Use the pedestrian route
	Wear protective clothing		Use the handrail
	Wear face shield		Wash your hands

11.2.4 Hazard symbols

	Gases under pressure		Acute, long-term hazard to the aquatic environment
	General safety notice		Oxidizing gases, solids
	Explosive substances/preparations and articles containing explosives Self-reactive substances and mixtures		Acute toxicity
	Flammable liquids, gases, solids		Corrosive to metals, etching/irritant effect on the skin, serious eye damage/eye irritation
	Respiratory/skin sensitization		

11.2.4.1 Fire prevention symbols

	Fire extinguisher		Fire alarm telephone
	Extinguishing hosepipe		Fire alarm
	Fire ladder		Direction indicator
	Fire-fighting agents and equipment		Direction indicator

11.2.5 Rescue symbols

	Escape routes/Emergency exit (left)		Emergency shower
	Escape routes/Emergency exit (right)		Stretcher
	First aid		Emergency escape with fire escape ladder
	Emergency phone		Rescue route exit
	Gathering place		Escape routes/Emergency exit with additional symbol (directional arrow)
	Doctor		Eye wash station
	Automatic external defibrillator (AED)		

11.2.6 Other symbols

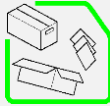
	Recycling		Dispose of packaging material in the appropriate manner
---	-----------	--	---

11.3 Further documents

Supplementary documentation, such as plans and drawings, as well as the delivery documentation of the purchased parts, are an integral part of the technical documentation of the machine.

The documents are stored in alphabetical order in numbered folders.

NOTICE



Ensure completeness of the documents

- It is very important to ensure that the documents are complete!
- Any missing documents must be replaced without delay with a copy!

11.4 Plans (Lubrication)

11.5 Drawings (Electrical circuit diagrams)

11.6 Spare parts lists

Pneumatik 5700_5710

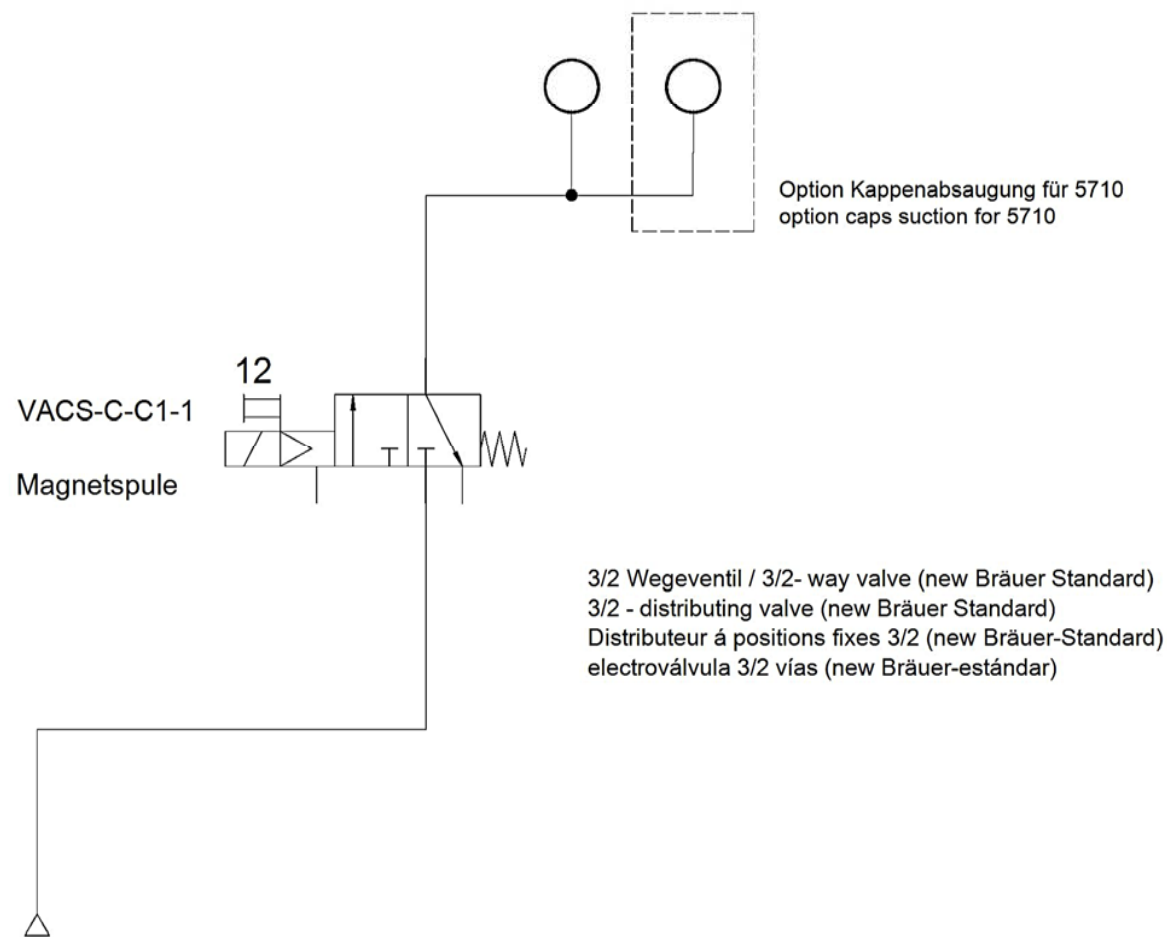

Druckluftanschluss (kundenseitig) G1/8" Innengewinde , 4-6bar
compressed Air (customer) G 1/8" internal thread, 4-6bar
connexion pour l'air comprimé (client) G1/8" Filetage intérieur, 4-6bar

				Datum	Name		Projekt	Kappostar	Anlage		
			Gezeich.	17.05.2017	Häßler				Ort	Mildenau	
			Gesehen				Titel	Pneumatikplan PV 5700_5710		Maßstab	Blatt 1
r.	Änderung	Datum	Name	Freigabe					von	1	



Braeuer Systemtechnik GmbH

Gewerbegebiet Nord 6
09456 Mildenau

Tel: 0049 3733 5967610
Fax: 0049 3733 5967611

Projektnummer NSB-5700-037.01
Gerätename Kappenwechsler BKS 5700/5710 ...

Pfad K:\EplanP8_2.6\STAMMDATEN\Projekte\Braeuer_Systemtechnik\Kappenwechsler
Projektverantwortlicher Hr. Sander

Erstellt am 21.06.2013
Bearbeitet am 08.03.2018 von (Kürzel) Rico Sander

			Datum	15.08.2012	Kappenwechsler BKS 5700/5710 ...	 Braeuer Systemtechnik GmbH Gewerbegebiet Nord 6 09456 Mildenau Tel: 0049 3733 5967610 Fax: 0049 3733 5967611	Titel- / Deckblatt	=		
		Bearb.	Rico Sander	+						
		Gepr								
Anderung	Datum	Name	Urspr						NSB-5700-037.01	Blatt Blatt

Bräuer Systemtechnik GmbH

Gewerbegebiet Nord 6, 09456 Mildenaу, Germany



contact: info@braeuersysteme.de
homepage: www.braeuersysteme.de

list of spare parts for:

cap changing system

5005710037000 / 5005710037004

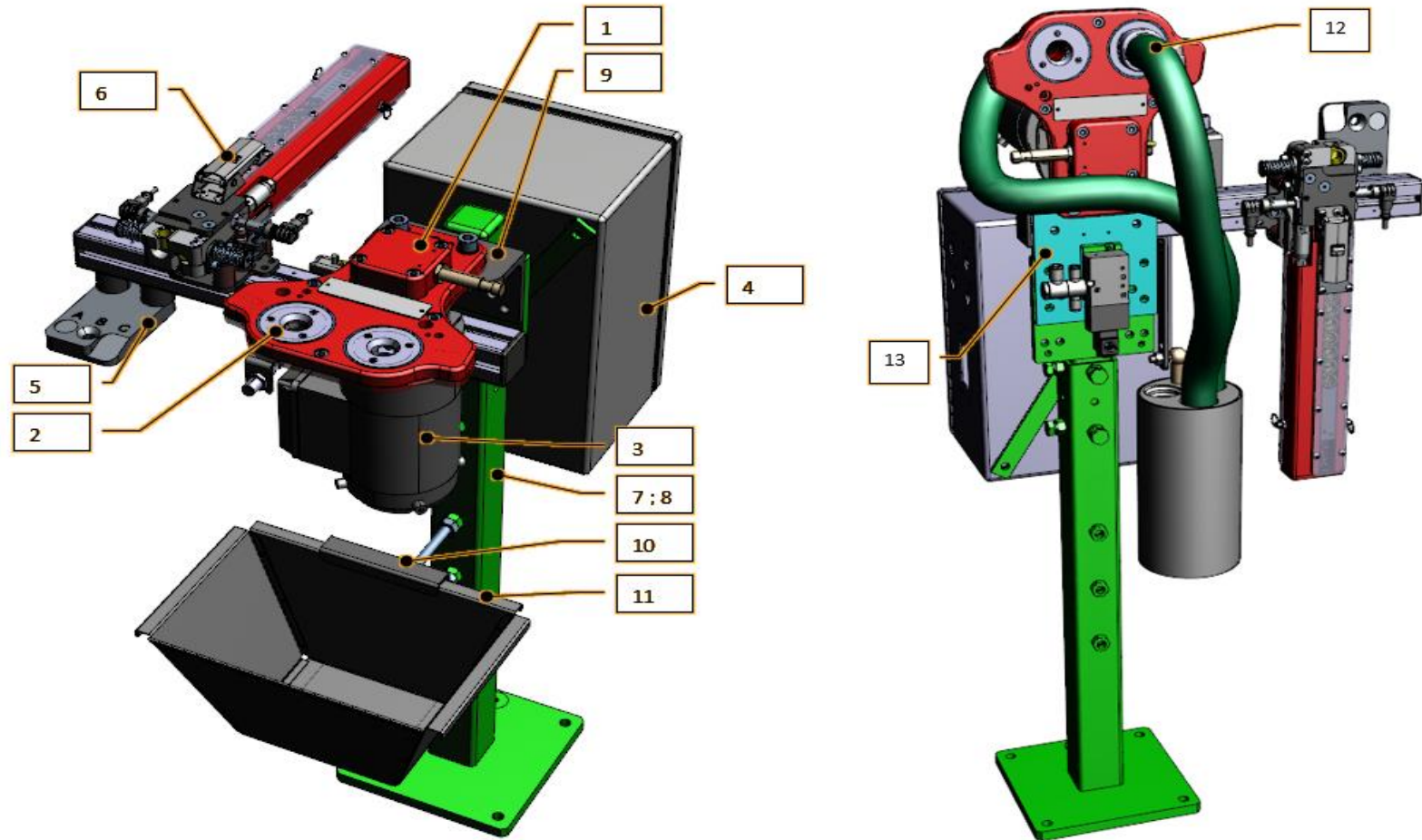

pos.	quantity	description	item number	additional information
1	1,00 pc	gear unit	81656000000002	-
2	2,00 pc	cap changing head	-	depent on cap-size
3	1,00 pc	drive unit	86905000060001	-
4	1,00 pc	electrical switch box	86057003701	NSB-5700-037.01
5	1,00 pc	holder	50056400100119	-
6	1,00 pc	cap cartridge	-	depent on cap-size
7	1,00 pc	height-adjustable leg stand	89040590000700	-
8	1,00 pc	sealing plug	88100000002800	-
9	1,00 pc	vertical angle	89040000010017	5005710037000
10	1,00 pc	holder of the cap box	87030000007076	5005710037000
11	1,00 pc	cap collecting box	50500000004000	5005710037000
12	1,00 pc	cap suction unit	50056100034014	(5005710037004) Ø13mm-Ø16mm
13	1,00 pc	plate	80540000010019	5005710037004
o.P.	1,00 pc	connecting cable	860418	-

Bräuer Systemtechnik GmbH

Gewerbegebiet Nord 6, 09456 Mildenaу, Germany



contact: info@braeuersysteme.de
homepage: www.braeuersysteme.de

list of spare parts for:

gear unit

8165600000002

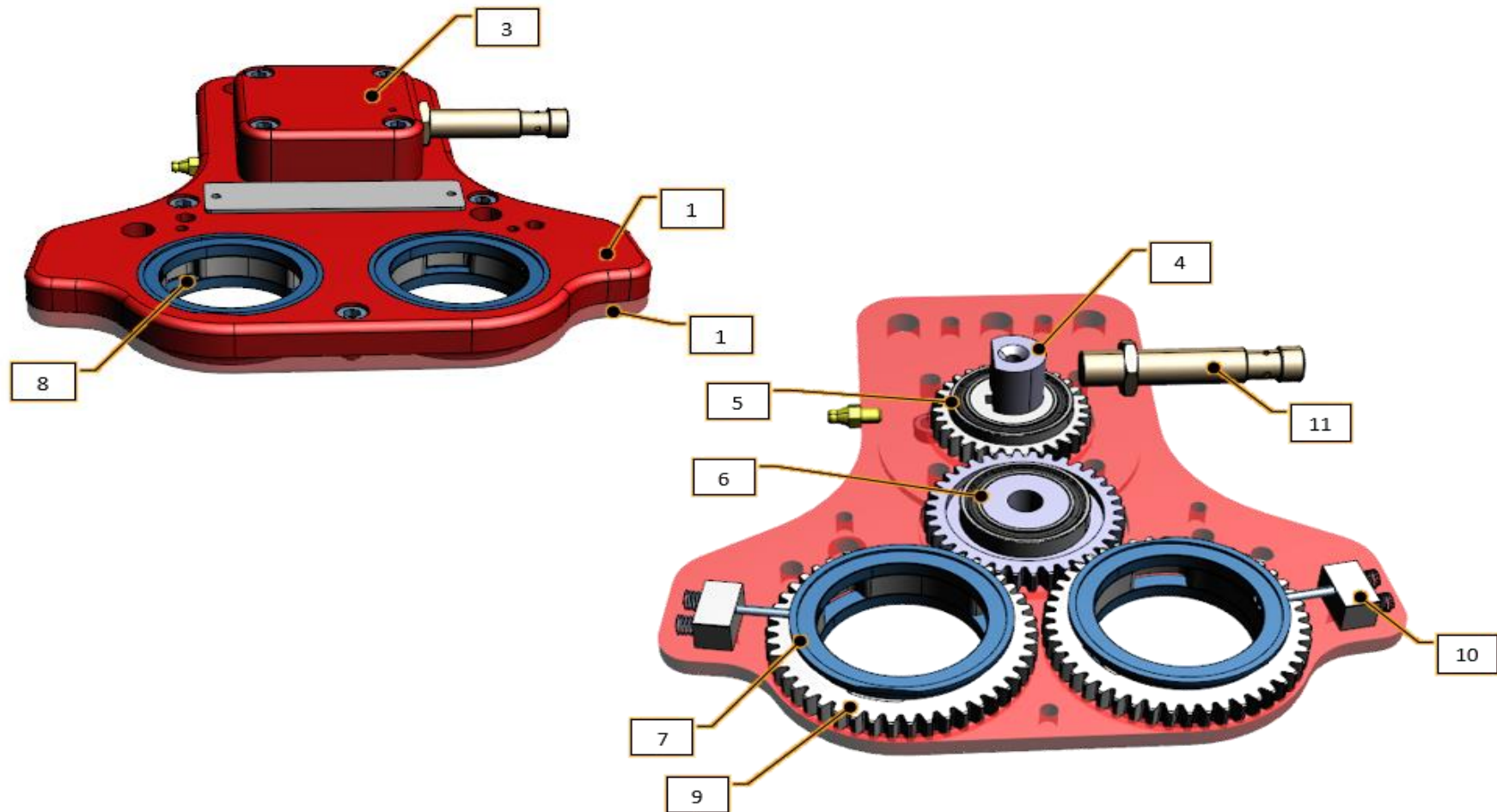

pos.	quantity	description	item number	additional information
1	1,00 pc	top plate	50557100005007	-
2	1,00 pc	bottom plate	50557100005006	-
3	1,00 pc	protection	50557000005006	-
4	1,00 pc	sensor ring	50557000005007	-
5	1,00 pc	gear wheel/ ball bearing bundle	80530000099013	-
6	1,00 pc	gear wheel/ ball bearing bundle	80530000099012	-
7	2,00 pc	sliding bushing	50557100002011	-
8	2,00 pc	sliding bushing	50557100002022	-
9	2,00 pc	gear wheel	50557100002010	-
	4,00 pc	compressing spring	50500000000600	-
10	2,00 pc	cylindrical pin	306325030300	-
	2,00 pc	spring block	50557100002005	-
11	1,00 pc	sensor	86200000000100	-

Bräuer Systemtechnik GmbH

Gewerbegebiet Nord 6, 09456 Mildenaу, Germany



contact: info@braeuersysteme.de
homepage: www.braeuersysteme.de

list of spare parts for:

cap changing head

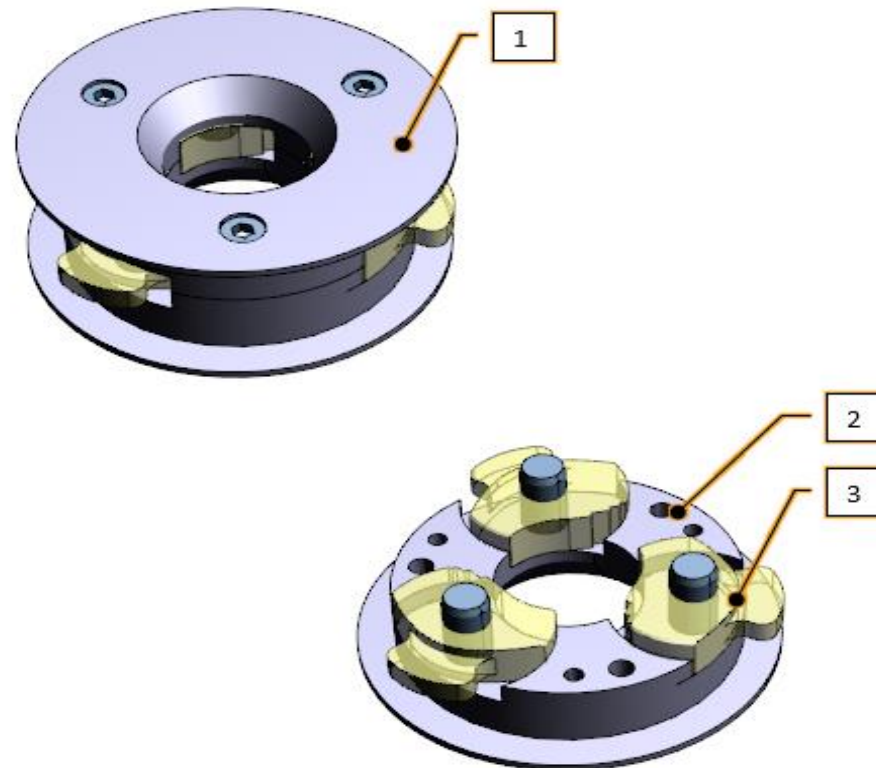

pos.	quantity	description	item number	additional information
	1,00 pc	cap changing head	530571300200	Ø13
1	1,00 pc	cap changing head	530571600200	Ø16
	1,00 pc	cap changing head	530572000200	Ø20
	2,00 pc	bushing	50557100002014	Ø13
2	2,00 pc	bushing	50557100002017	Ø16
	2,00 pc	bushing	50557100002021	Ø20
	3,00 pc	gripper	50557100002013	Ø13
3	3,00 pc	gripper	50557100002016	Ø16
	3,00 pc	gripper	50557100002020	Ø20

Bräuer Systemtechnik GmbH

Gewerbegebiet Nord 6, 09456 Mildenaу, Germany



contact: info@braeuersysteme.de
homepage: www.braeuersysteme.de

list of spare parts for:

holder

50056400100119

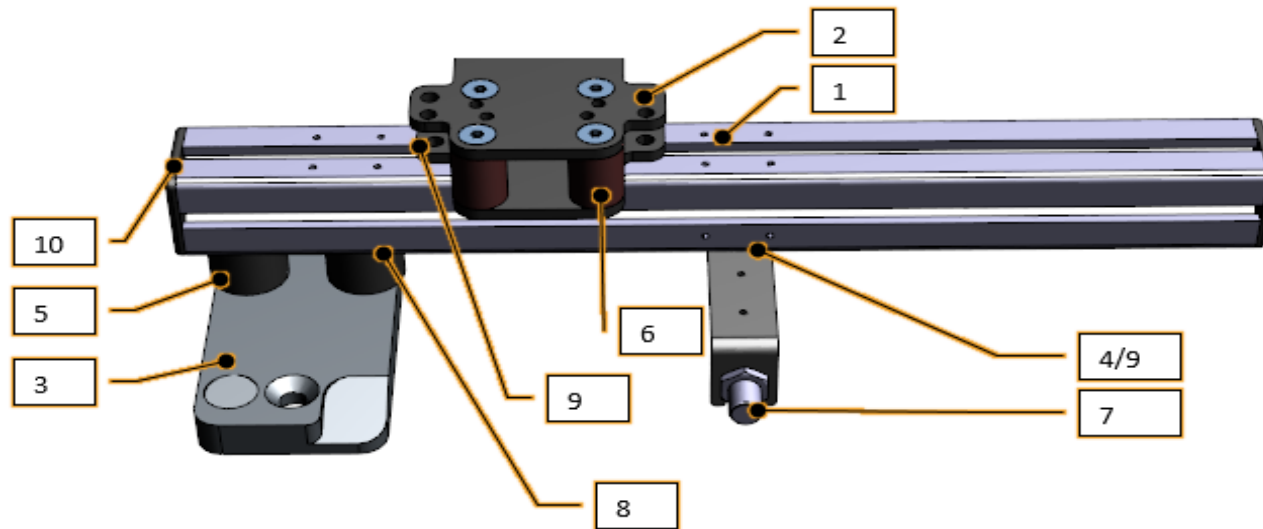

pos.	quantity	description	item number	additional information
1	1,00 pc	square tube	50556100005273	0
2	2,00 pc	compensating plate	50556100005066	5610/05/066/02 Ausgleich
3	1,00 pc	cap seating plate	87030000007067	3000/07/067/02
4	1,00 pc	sensor angle	87030000007065	3000/07/065/05
5	2,00 pc	rubber bumper	80500000000800	0
6	6,00 pc	rubber bumper	80500000000100	0
7	1,00 pc	sensor	86200000000100	0
8	4,00 pc	t-nut	88100000000100	0
9	3,00 pc	t-nut	50500000001200	0
10	2,00 pc	sealing plug	50500000000300	0

Bräuer Systemtechnik GmbH

Gewerbegebiet Nord 6, 09456 Mildenaу, Germany



contact: info@braeuersysteme.de
homepage: www.braeuersysteme.de

list of spare parts for:

cap suction unit

50056100034014

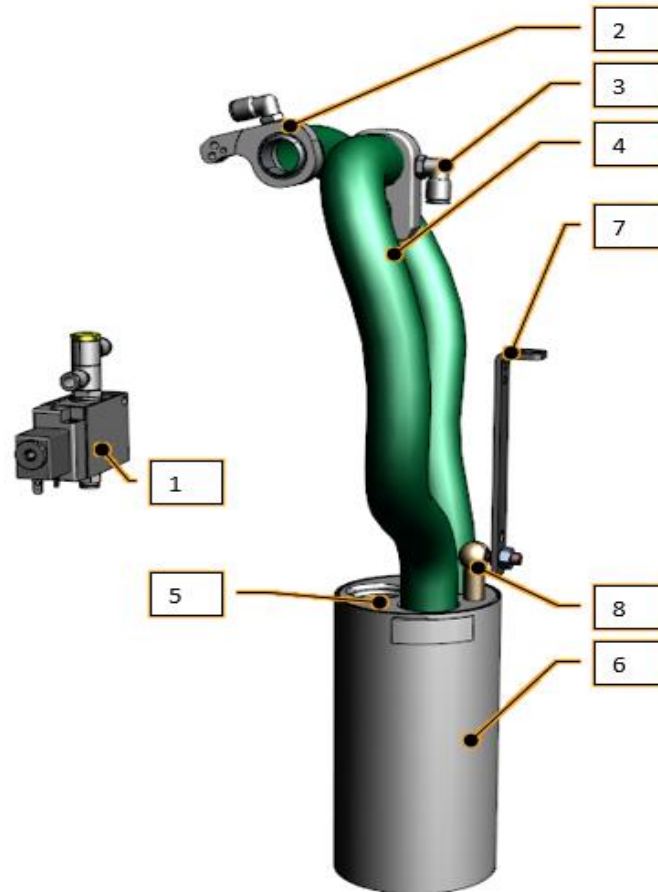

pos.	quantity	description	item number	additional information
1	1,00 pc	pneumatic valve	87030000007111	3/2 G-1/8
2	2,00 pc	basic unit	50558100001011	5810/01/011/04
3	2,00 pc	elbow gland	87100000002000	G1/8a-Ø 8
4	2,00 pc	plastic tube	30000000004300	Øi32mm PVC # 430mm
5	1,00 pc	retainer	85141000000023	4100/000/23/01
6	1,00 pc	swarf bag	85100000000500	Ø100 200x105mm
7	1,00 pc	holder	85136000001010	3600/01/010/03
8	1,00 pc	angle-joint for swarf bag holder	37180208CS001	

Bräuer Systemtechnik GmbH
Gewerbegebiet Nord 6
09456 Mildenau
Germany

Telephone: +49 (0) 3733/5967610
Fax: +49 (0) 03733/5967611
Email: info@braeuersysteme.de

